

MOUNTING INSTRUCTIONS

Standard Mounting Bracket

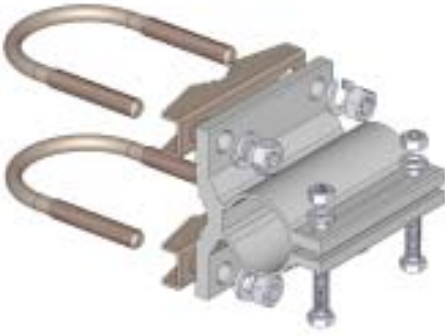

Spare parts: p/n SA197

Materials: extruded aluminum
Hardware: stainless & zinc plated steel
Dimensions : 80 x 76 x 65 mm
Weight: 460 gr

Part List

Q.ty	Description
1	Extruded aluminium bracket
2	Steel bracket
2	M8x200 U-bolt
4	M8 Grower washer
4	M8 Hexagonal nut
2	M6x20 Hexagonal head screw
2	M6 Grower washer
2	M6 Hexagonal nut

Tilting Bracket*



Order p/n: 2519803.00

Materials & Hardware: zinc plated steel
Dimensions: 110 x 150 x 6 mm.
Weight: 800 gr

Part List

Q.ty	Description
1	110x150x6 Tilting bracket
4	M8x25 Spheric head screw
4	M8 Grower washer
4	M8 Hexagonal nut

Mounting example

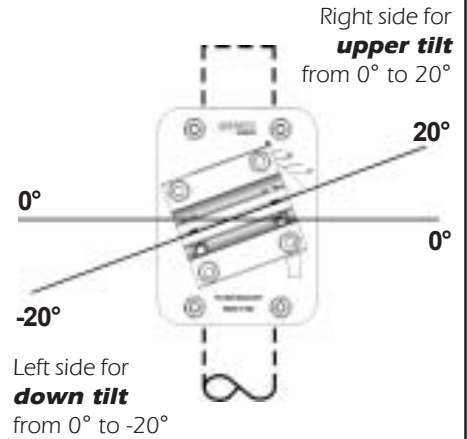

* **Optional (not included).**

Connector protection cap

Spare parts: p/n TE06416

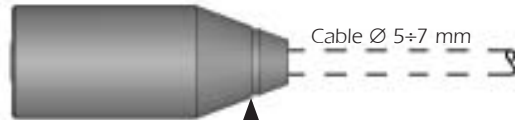

↑ Cut here for \varnothing 10mm cable or more

Stacking and Baying distance

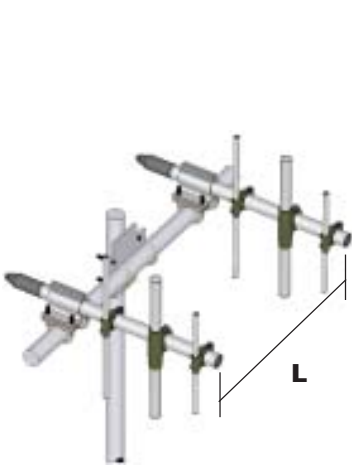

Vertical polarization
(Bayed)
L = 1.1 m

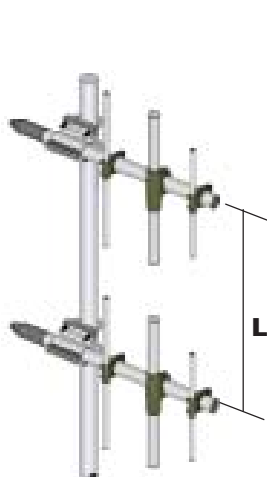

Vertical polarization
(Stacked)
L = 1.6 m

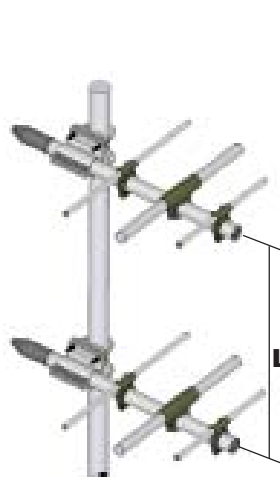

Horizontal polarization
(Stacked)
L = 1.1 m

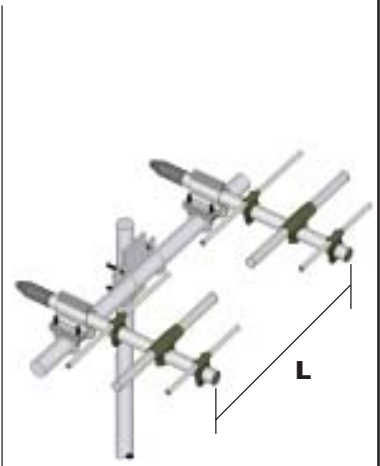

Horizontal polarization
(Bayed)
L = 1.6 m

WY140-6N

140-160 MHz Base Station 6 Element Yagi Antenna

DESCRIPTION

Base station antenna conceived by using an innovative feed system studied and applied to have highly symmetrical radiation pattern in both planes (E and H). It's completely computer designed to get high performances of gain and front-to-back in the working band. All aluminium parts are protected by anodized treatment, hardware are of Stainless steel or zinc plated steel, mounting bracket is of extruded aluminium for the best strength and the connector is placed in rear position for an easily access. To increase the antenna gain please install it in stacked or bayed array. **Patent pending applied.**



TECHNICAL DATA

Electrical Data

Type	6 elements Yagi
Frequency range	140 - 160 MHz
Impedance	50 Ω Unbalanced
Polarization	Linear Vertical or Horizontal
Radiation (H-plane)	beamwidth at -3 dB= 80° at 150 MHz
Radiation (E-plane)	beamwidth at -3 dB= 60° at 150 MHz
Max Gain	10.5 dBi
Front to Back ratio	\geq 16 dB
S.W.R. in bandwidth	\leq 1.5:1
Max Power	200 Watts (CW) at 30°C
Feed system / Position	RG303 Teflon coax with balun / inside boom
Lightning protection	DC-ground
Connector	N-female with rubber protection cap

Mechanical Data

Materials	Anodized 6063-T5 Aluminium, Thermoplastic UV stabilized, Chromed Brass
Wind load / resistance	184 N at 150 Km/h / 120 Km/h
Wind surface	0.150 m ²
Dimensions (approx.)	2010 x 1085 mm
Weight (approx.)	2440 gr
Turning radius	1940 mm
Operating temperature	-40° C to +60° C
Mounting Mast	\varnothing 35-52 mm

TYPICAL RADIATION PATTERN at 150 MHz

File: E-02-047 Scale: logarithmic

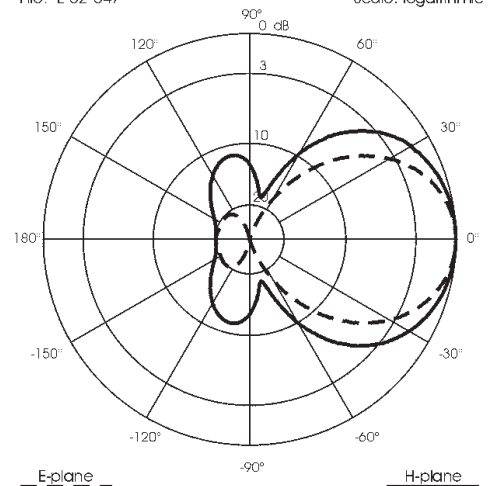

TYPICAL GAIN DIAGRAM vs FREQUENCY

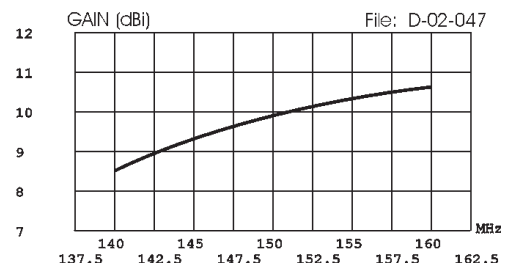

TYPICAL S.W.R. RESPONSE

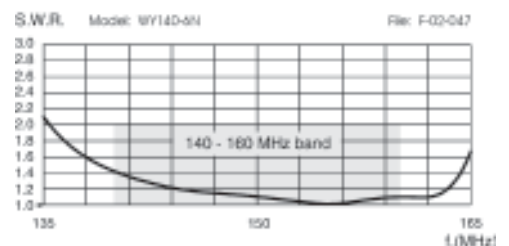

MOUNTING INSTRUCTIONS

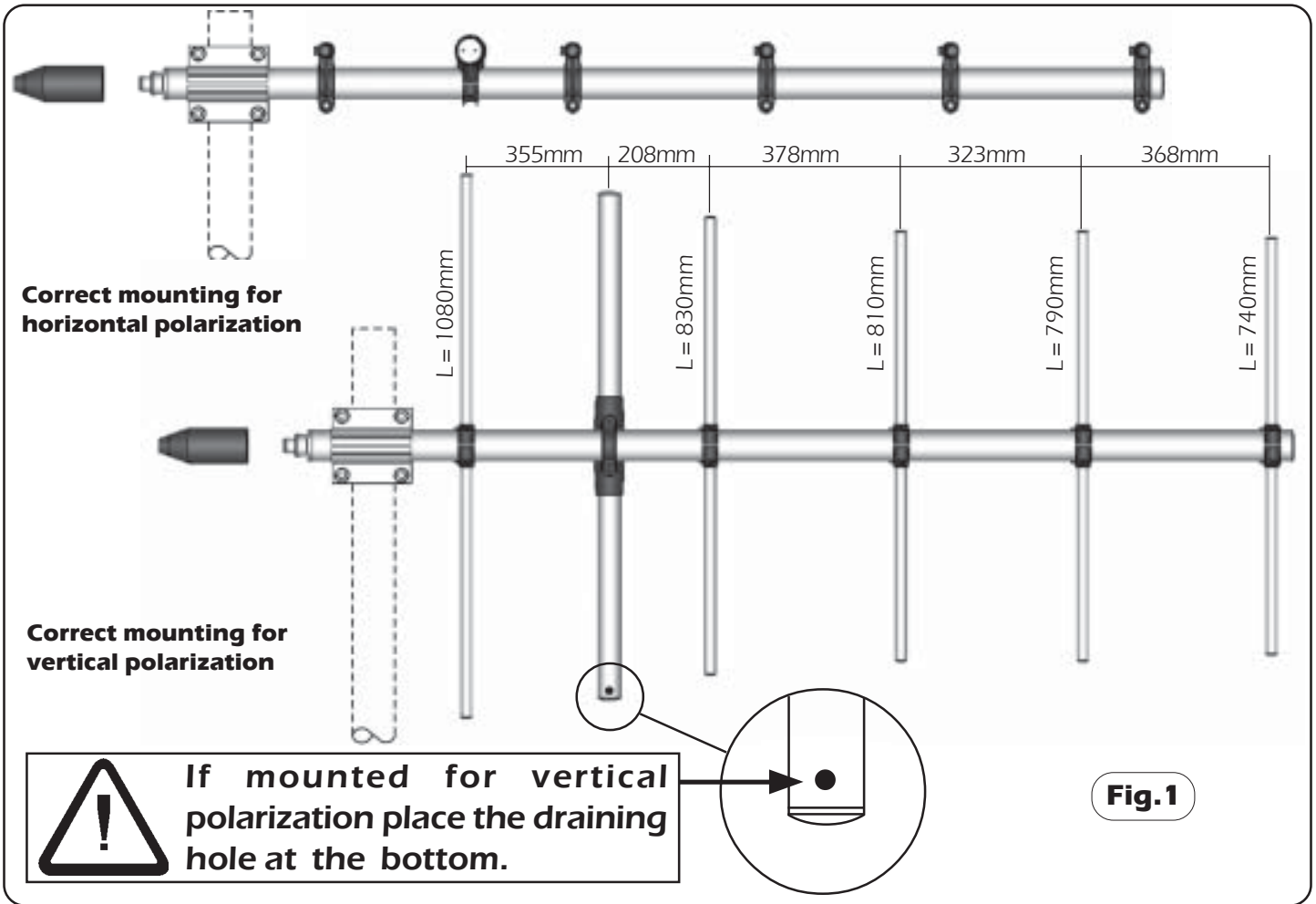

Element Mounting

1) By means of a meter measure the aluminium elements **A** and position them in the plastic support **B** of the boom according to **fig. 1**.

2) Place the reference marker of the aluminium element **A** in the centre of the plastic support **B** (see **fig. 3**) and lock the screws **C** by the supplied key **D** (**fig. 4**). When the screws touch the aluminium tubes you can finally lock them turning for 1.5 turns.

Warning: do not exceed 1.5 turns. The plastic support threads could be damaged.

3) Insert the plastic caps **E** on the aluminium elements **A** (see **fig. 4**)

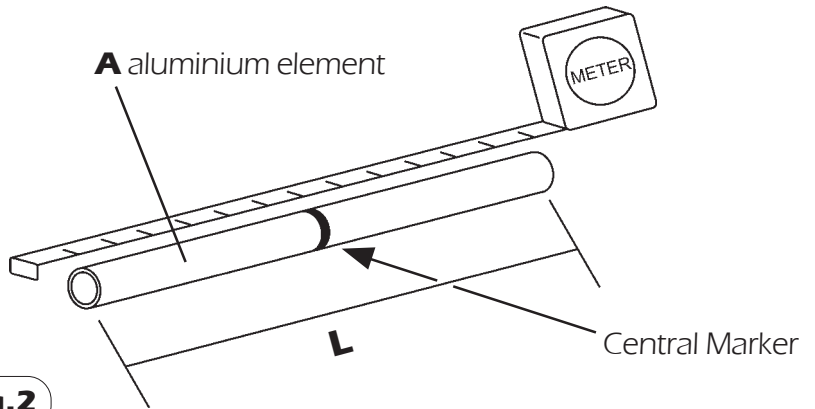

Fig.2

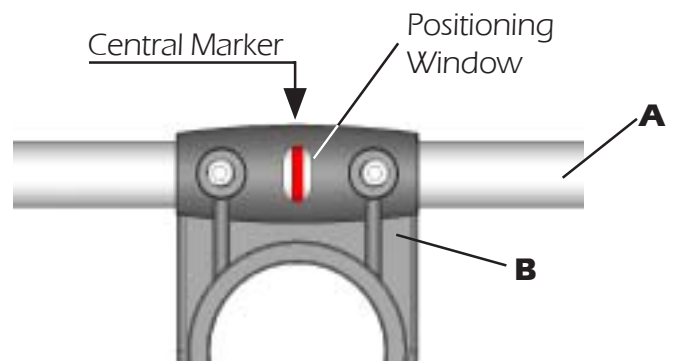

Fig.3

Part List

Q.ty	Description
5	A) Aluminium tubes (5 different length)
10	C) M5x6 Hexagon socket set screw
1	D) 2.5mm Hexagonal key
10	E) Plastic cap

MOUNTING INSTRUCTIONS

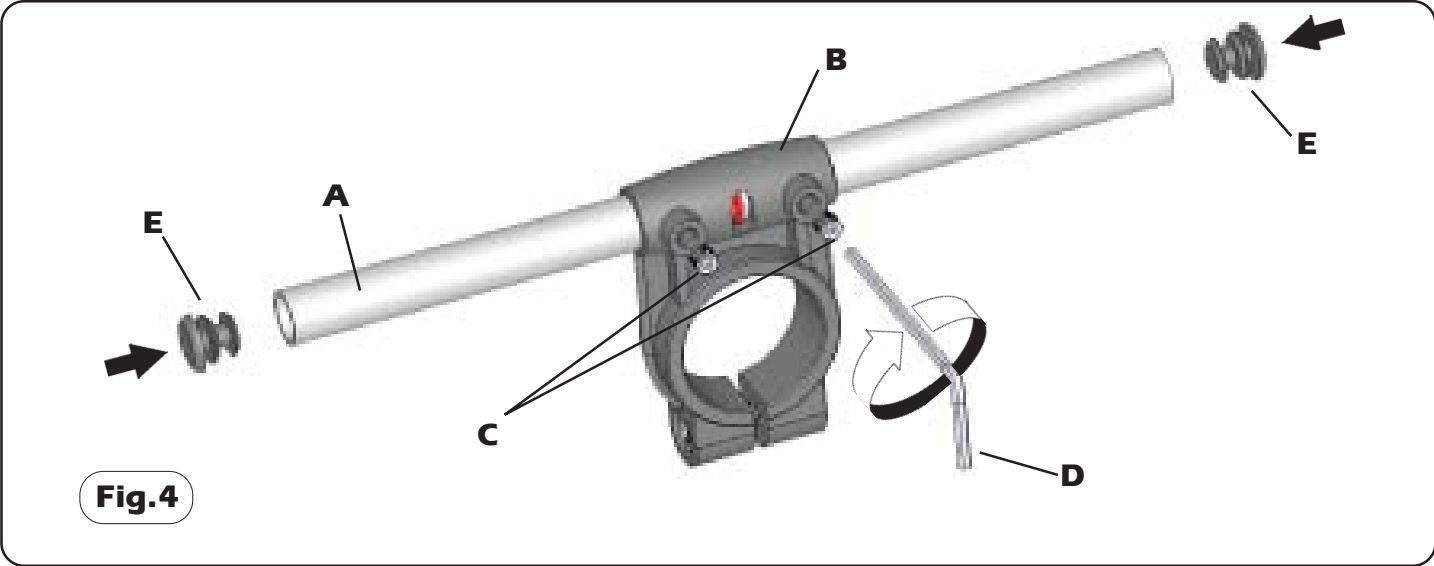
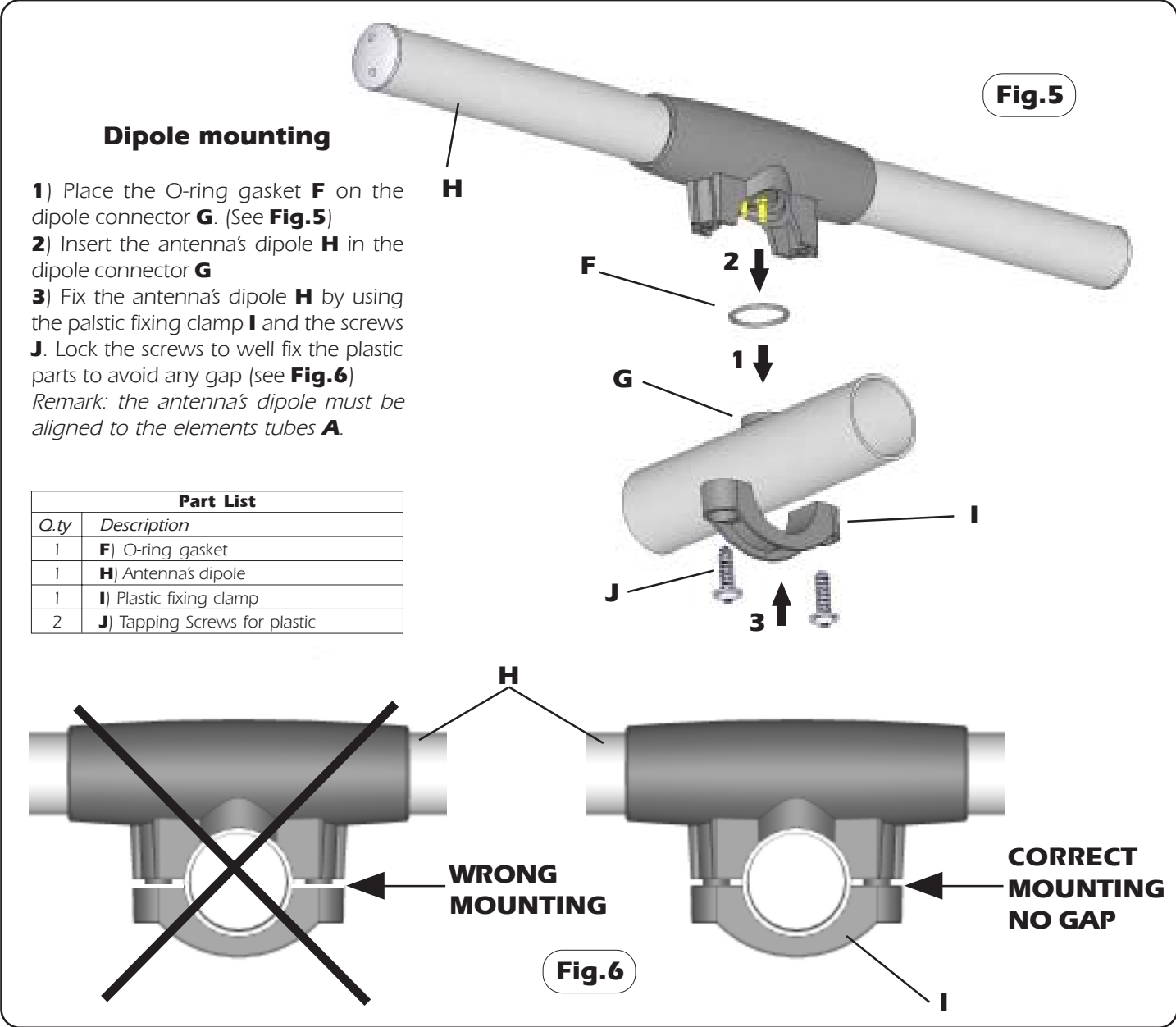
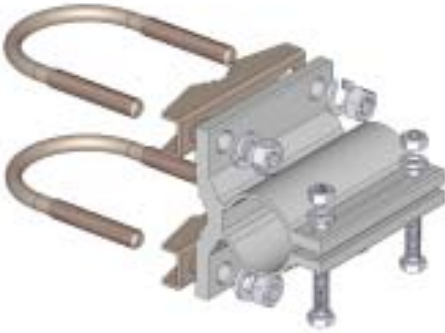

Fig.4



MOUNTING INSTRUCTIONS

Standard Mounting Bracket



Spare parts: p/n SA197

Materials: extruded aluminum
Hardware: stainless & zinc plated steel
Dimensions : 80 x 76 x 65 mm
Weight: 460 gr

Part List

Q.ty	Description
1	Extruded aluminium bracket
2	Steel bracket
2	M8x200 U-bolt
4	M8 Grower washer
4	M8 Hexagonal nut
2	M6x20 Hexagonal head screw
2	M6 Grower washer
2	M6 Hexagonal nut

Tilting Bracket*



Order p/n: 2519803.00

Materials & Hardware: zinc plated steel
Dimensions: 110 x 150 x 6 mm.
Weight: 800 gr

Part List

Q.ty	Description
1	110x150x6 Tilting bracket
4	M8x25 Spheric head screw
4	M8 Grower washer
4	M8 Hexagonal nut

Mounting example

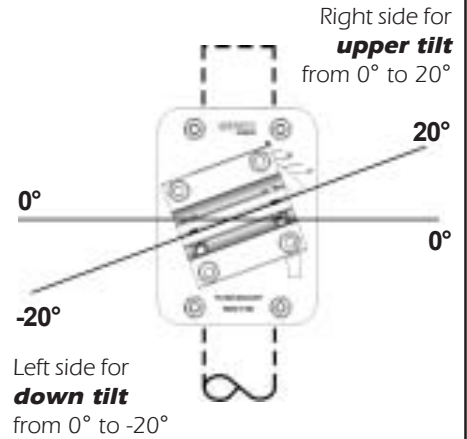

* **Optional (not included).**

Connector protection cap

Spare parts: p/n TE06416

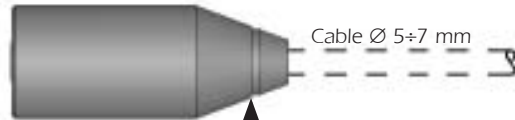

↑ Cut here for Ø 10mm cable or more

Stacking and Baying distance

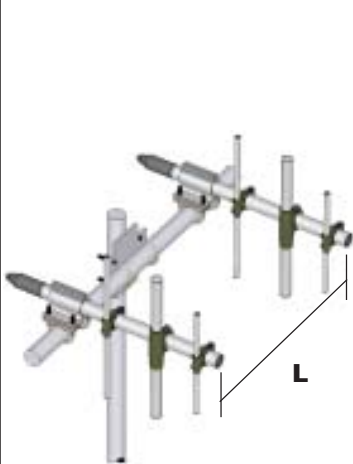

Vertical polarization
(Bayed)
L = 1.1 m



Vertical polarization
(Stacked)
L = 1.6 m

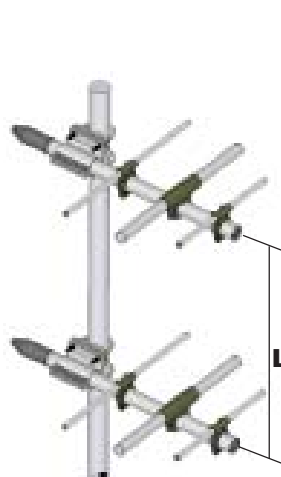

Horizontal polarization
(Stacked)
L = 1.1 m

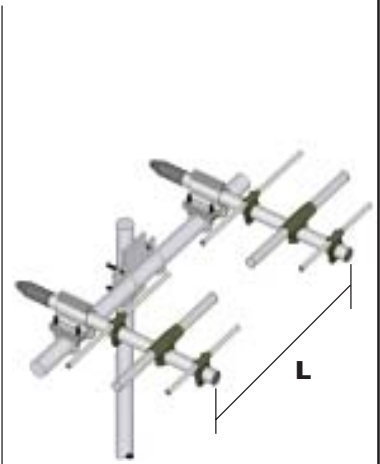

Horizontal polarization
(Bayed)
L = 1.6 m



SIRIO
antenne

HI-QUALITY ANTENNAS MADE IN ITALY

WY155-6N

155-175 MHz Base Station 6 Element Yagi Antenna

DESCRIPTION

Base station antenna conceived by using an innovative feed system studied and applied to have highly symmetrical radiation pattern in both planes (E and H). It's completely computer designed to get high performances of gain and front-to-back in the working band. All aluminium parts are protected by anodized treatment, hardware are of Stainless steel or zinc plated steel, mounting bracket is of extruded aluminium for the best strength and the connector is placed in rear position for an easily access. To increase the antenna gain please install it in stacked or bayed array. **Patent pending applied.**



TECHNICAL DATA

Electrical Data

Type	6 elements Yagi
Frequency range	155 - 175 MHz
Impedance	50 Ω Unbalanced
Polarization	Linear Vertical or Horizontal
Radiation (H-plane)	beamwidth at -3 dB= 75° at 165 MHz
Radiation (E-plane)	beamwidth at -3 dB= 55° at 165 MHz
Max Gain	10.5 dBi
Front to Back ratio	≥ 16 dB
S.W.R. in bandwidth	$\leq 1.5:1$
Max Power	200 Watts (CW) at 30°C
Feed system / Position	RG303 Teflon coax with balun / inside boom
Lightning protection	DC-ground
Connector	N-female with rubber protection cap

Mechanical Data

Materials	Anodized 6063-T5 Aluminium, Thermoplastic UV stabilized, Chromed Brass
Wind load / resistance	176 N at 150 Km/h / 120 Km/h
Wind surface	0.145 m ²
Dimensions (approx.)	2010 x 985 mm
Weight (approx.)	2395 gr
Turning radius	1930 mm
Operating temperature	-40° C to +60° C
Mounting Mast	\varnothing 35-52 mm

TYPICAL RADIATION PATTERN at 165 MHz

File: E-02-052 Scale: logarithmic

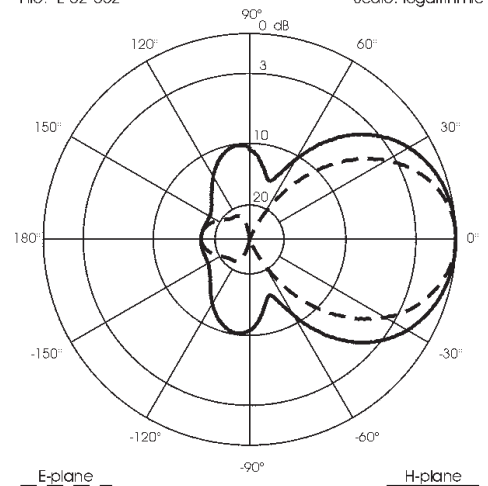

TYPICAL GAIN DIAGRAM vs FREQUENCY

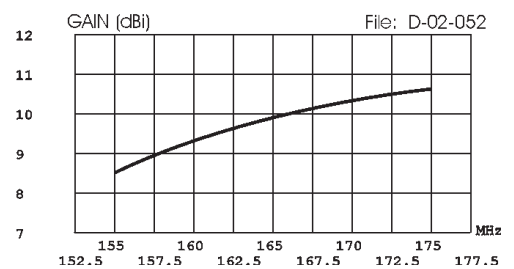

TYPICAL S.W.R. RESPONSE

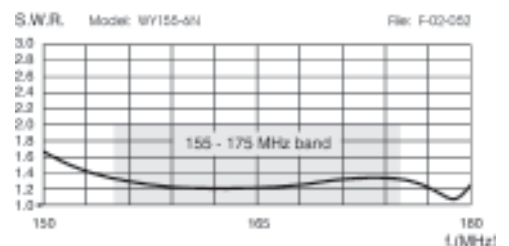

MOUNTING INSTRUCTIONS

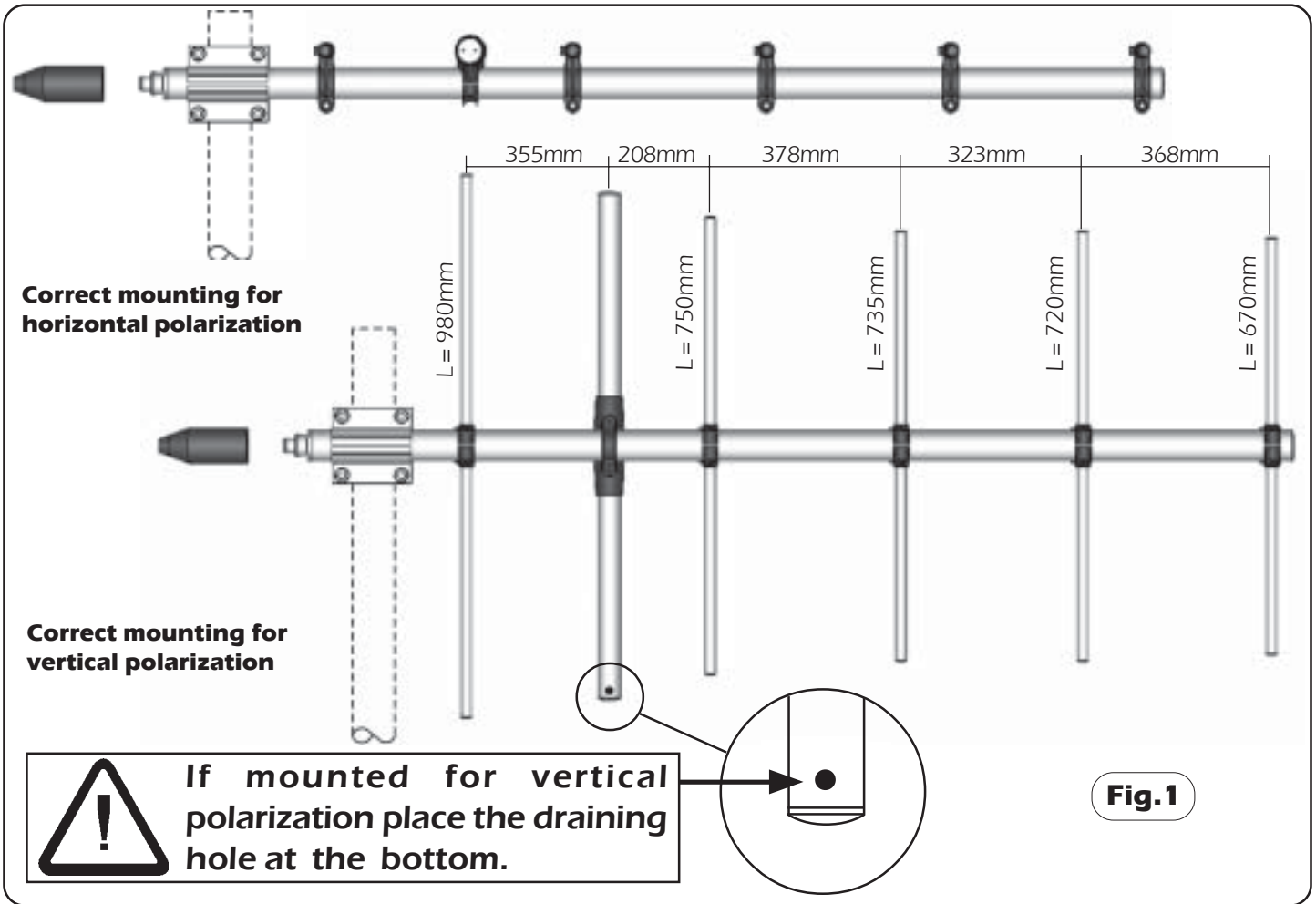

Element Mounting

1) By means of a meter measure the aluminium elements **A** and position them in the plastic support **B** of the boom according to **fig. 1**.

2) Place the reference marker of the aluminium element **A** in the centre of the plastic support **B** (see **fig. 3**) and lock the screws **C** by the supplied key **D** (**fig. 4**). When the screws touch the aluminium tubes you can finally lock them turning for 1.5 turns.

Warning: do not exceed 1.5 turns. The plastic support threads could be damaged.

3) Insert the plastic caps **E** on the aluminium elements **A** (see **fig. 4**)

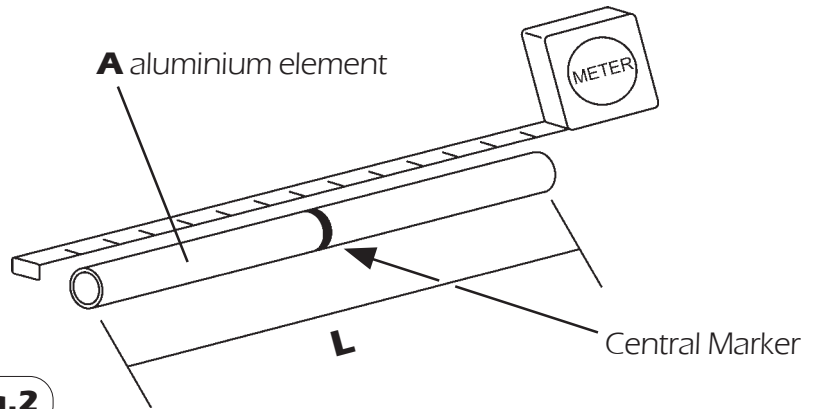

Part List	
Q.ty	Description
5	A) Aluminium tubes (5 different length)
10	C) M5x6 Hexagon socket set screw
1	D) 2.5mm Hexagonal key
10	E) Plastic cap

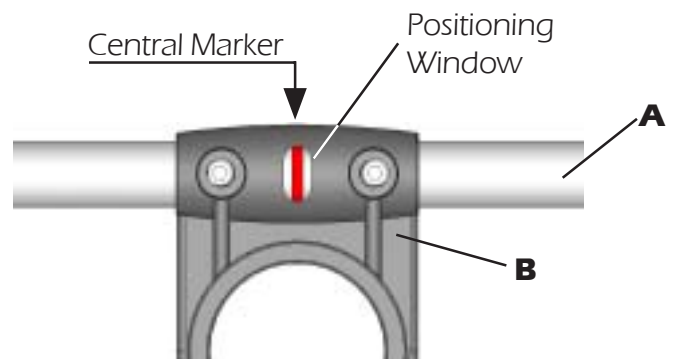

MOUNTING INSTRUCTIONS

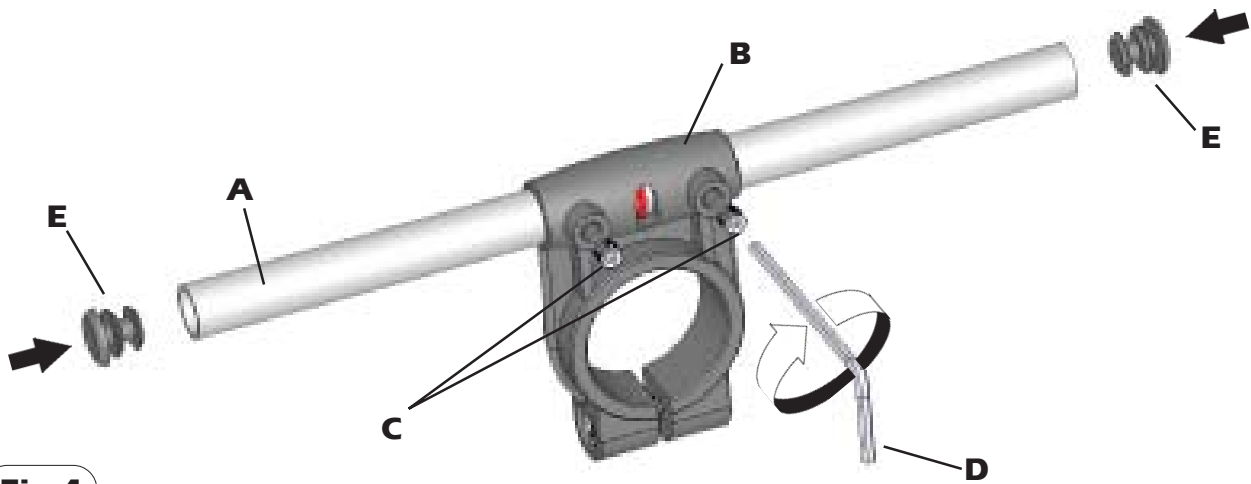

Fig.4

Dipole mounting

- 1) Place the O-ring gasket **F** on the dipole connector **G**. (See **Fig.5**)
 - 2) Insert the antenna's dipole **H** in the dipole connector **G**
 - 3) Fix the antenna's dipole **H** by using the plastic fixing clamp **I** and the screws **J**. Lock the screws to well fix the plastic parts to avoid any gap (see **Fig.6**)
- Remark: the antenna's dipole must be aligned to the elements tubes **A**.*

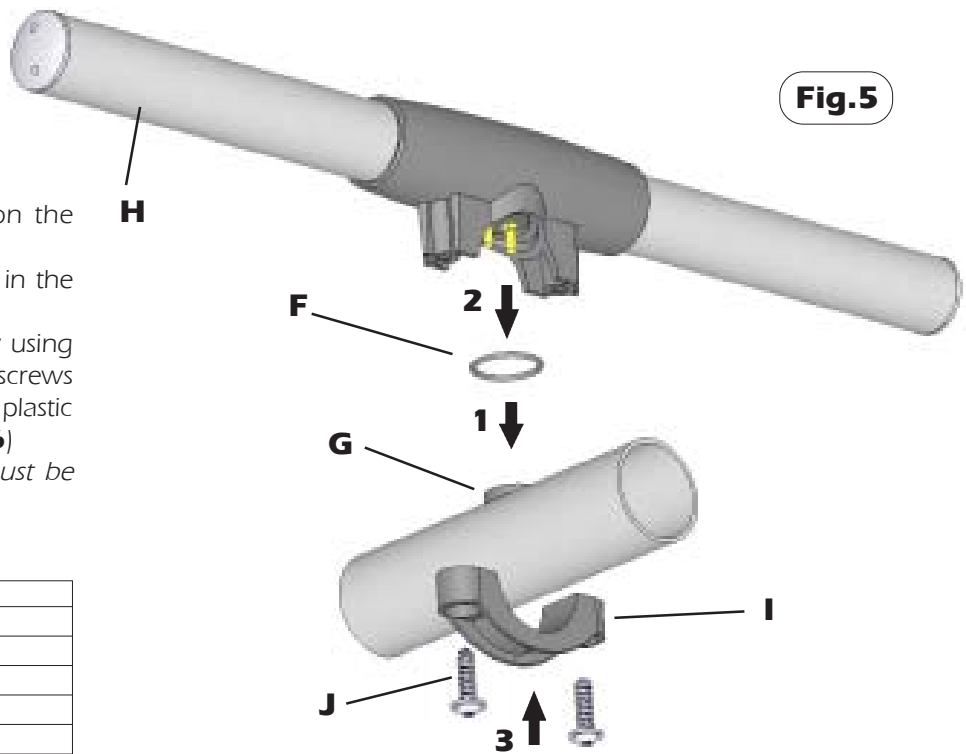

Fig.5

Part List	
Q.ty	Description
1	F) O-ring gasket
1	H) Antenna's dipole
1	I) Plastic fixing clamp
2	J) Tapping Screws for plastic

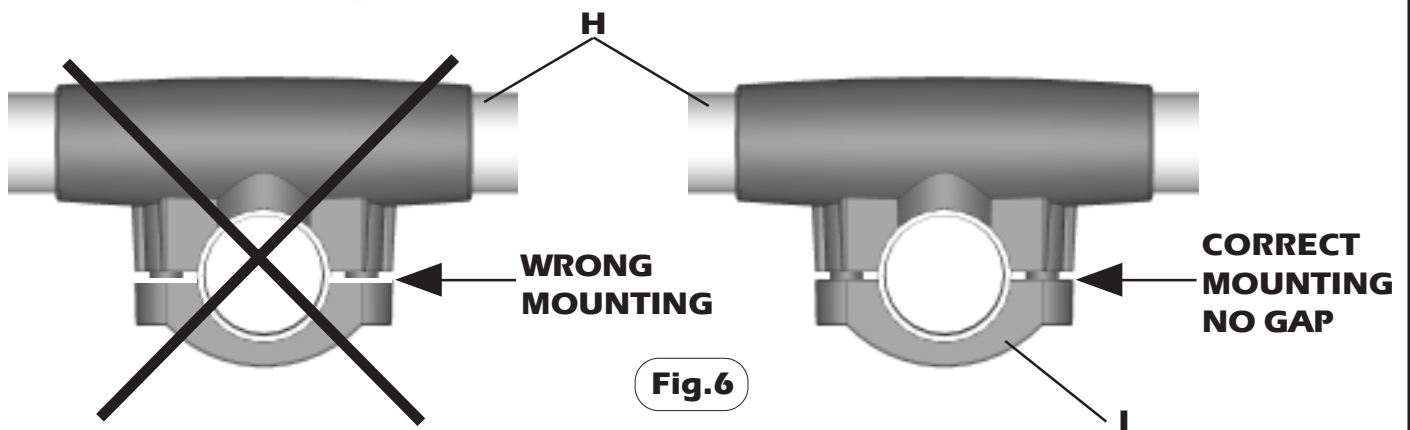

Fig.6