

# MOUNTING INSTRUCTIONS

## Standard Mounting Bracket

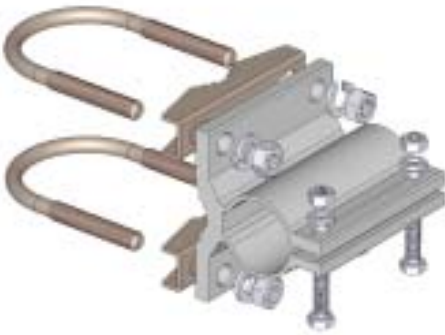

### Spare parts: p/n SA197

Materials: extruded aluminum  
Hardware: stainless & zinc plated steel  
Dimensions : 80 x 76 x 65 mm  
Weight: 460 gr

#### Part List

| Q.ty | Description                |
|------|----------------------------|
| 1    | Extruded aluminium bracket |
| 2    | Steel bracket              |
| 2    | M8x200 U-bolt              |
| 4    | M8 Grower washer           |
| 4    | M8 Hexagonal nut           |
| 2    | M6x20 Hexagonal head screw |
| 2    | M6 Grower washer           |
| 2    | M6 Hexagonal nut           |

## Tilting Bracket\*



### Order p/n: 2519803.00

Materials & Hardware: zinc plated steel  
Dimensions: 110 x 150 x 6 mm.  
Weight: 800 gr

#### Part List

| Q.ty | Description               |
|------|---------------------------|
| 1    | 110x150x6 Tilting bracket |
| 4    | M8x25 Spheric head screw  |
| 4    | M8 Grower washer          |
| 4    | M8 Hexagonal nut          |

## Mounting example

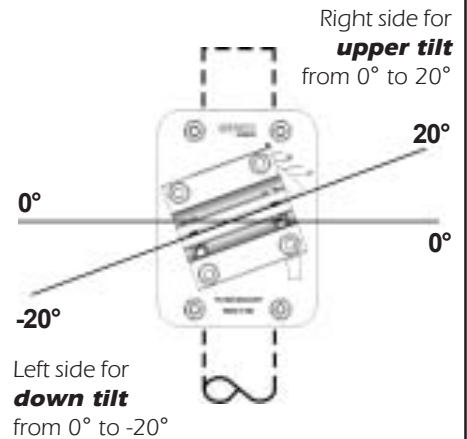

\* **Optional (not included).**

## Connector protection cap

Spare parts: p/n TE06416

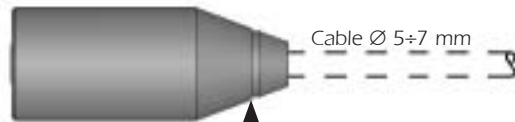

↑ Cut here for Ø 10mm cable or more

## Stacking and Baying distance

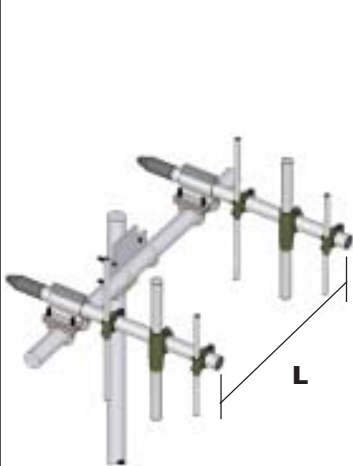

Vertical polarization  
(Bayed)  
**L = 1.1 m**



Vertical polarization  
(Stacked)  
**L = 1.6 m**

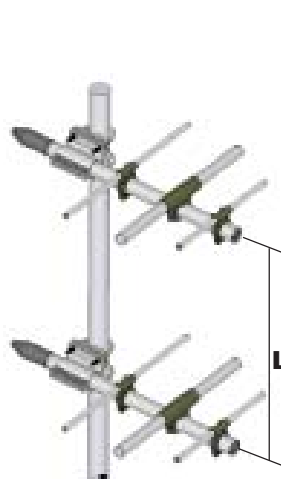

Horizontal polarization  
(Stacked)  
**L = 1.1 m**

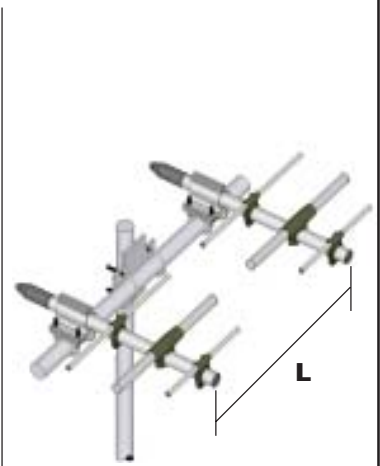

Horizontal polarization  
(Bayed)  
**L = 1.6 m**



**SIRIO**  
antenne

HI-QUALITY ANTENNAS MADE IN ITALY

# WY140-4N

## 140-160 MHz Base Station 4 Element Yagi Antenna

### DESCRIPTION

Base station antenna conceived by using an innovative feed system studied and applied to have highly symmetrical radiation pattern in both planes (E and H). It's completely computer designed to get high performances of gain and front-to-back in the working band. All aluminium parts are protected by anodized treatment, hardware are of Stainless steel or zinc plated steel, mounting bracket is of extruded aluminium for the best strength and the connector is placed in rear position for an easily access. To increase the antenna gain please install it in stacked or bayed array. **Patent pending applied.**

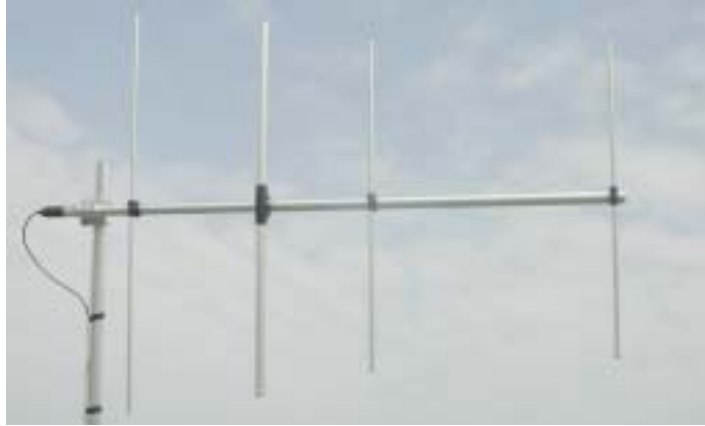

### TECHNICAL DATA

#### Electrical Data

|                        |  |
|------------------------|--|
| Type                   | 4 elements Yagi                            |
| Frequency range        | 140 - 160 MHz                              |
| Impedance              | 50 $\Omega$ Unbalanced                     |
| Polarization           | Linear Vertical or Horizontal              |
| Radiation (H-plane)    | beamwidth at -3 dB= 100° at 150 MHz        |
| Radiation (E-plane)    | beamwidth at -3 dB= 65° at 150 MHz         |
| Max Gain               | 8.5 dBi                                    |
| Front to Back ratio    | $\geq 16$ dB                               |
| S.W.R. in bandwidth    | $\leq 1.5:1$                               |
| Max Power              | 200 Watts (CW) at 30°C                     |
| Feed system / Position | RG303 Teflon coax with balun / inside boom |
| Lightning protection   | DC-ground                                  |
| Connector              | N-female with rubber protection cap        |

#### Mechanical Data

|                        |   |
|------------------------|---|
| Materials              | Anodized 6063-T5 Aluminium,<br>Thermoplastic UV stabilized, Chromed Brass |
| Wind load / resistance | 147 N at 150 Km/h / 140 Km/h  |
| Wind surface           | 0.119 m <sup>2</sup>  |
| Dimensions (approx.)   | 1600 x 1085 mm  |
| Weight (approx.)       | 2080 gr   |
| Turning radius         | 1540 mm   |
| Operating temperature  | -40° C to +60° C  |
| Mounting Mast          | $\varnothing$ 35-52 mm  |

TYPICAL RADIATION PATTERN at 150 MHz

File: E-02-046 Scale: logarithmic

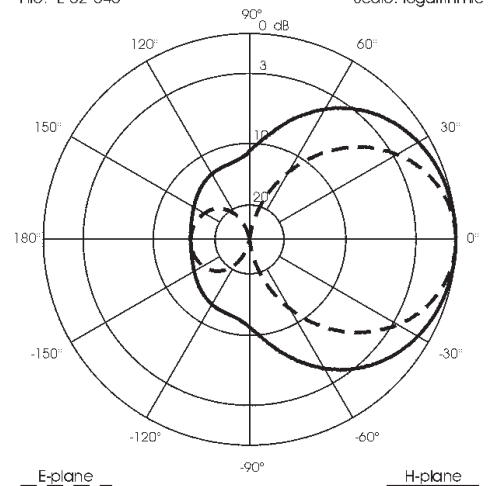

TYPICAL GAIN DIAGRAM vs FREQUENCY

GAIN (dBi) File: D-02-046

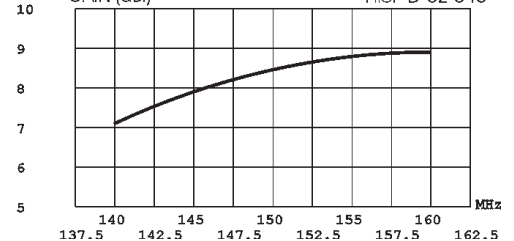

TYPICAL S.W.R. RESPONSE

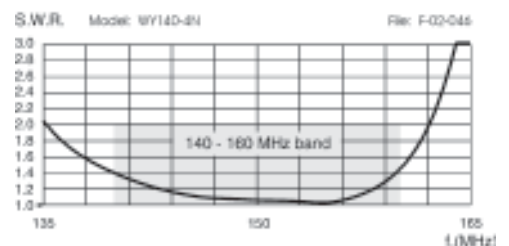

# MOUNTING INSTRUCTIONS

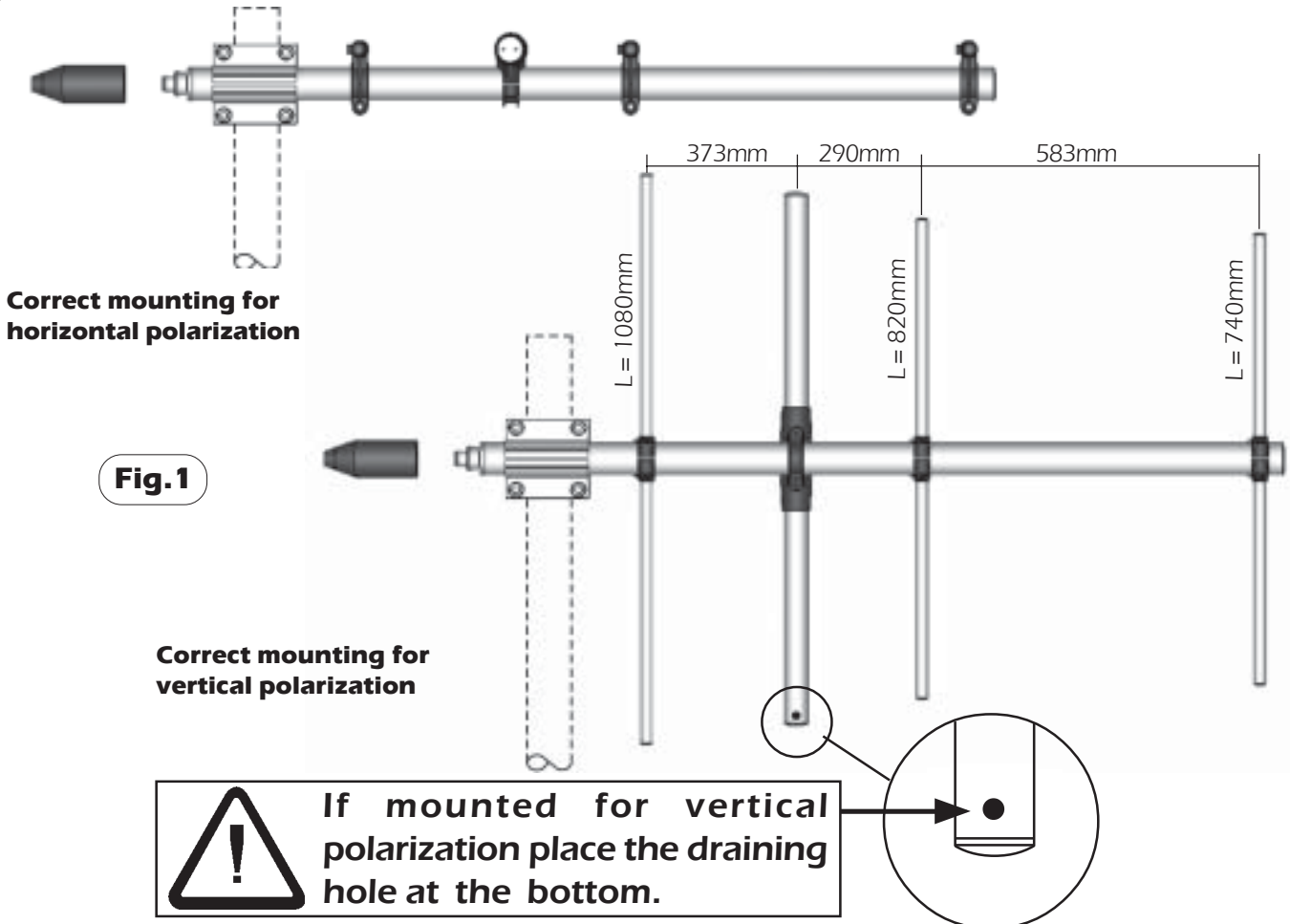

## Element Mounting

1) By means of a meter measure the aluminium elements **A** and position them in the plastic support **B** of the boom according to **fig. 1**.

2) Place the reference marker of the aluminium element **A** in the centre of the plastic support **B** (see **fig. 3**) and lock the screws **C** by the supplied key **D** (**fig. 4**). When the screws touch the aluminium tubes you can finally lock them turning for 1.5 turns.

**Warning: do not exceed 1.5 turns. The plastic support threads could be damaged.**

3) Insert the plastic caps **E** on the aluminium elements **A** (see **fig. 4**)

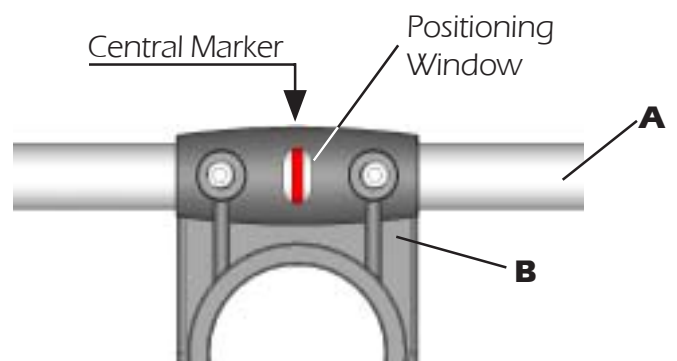
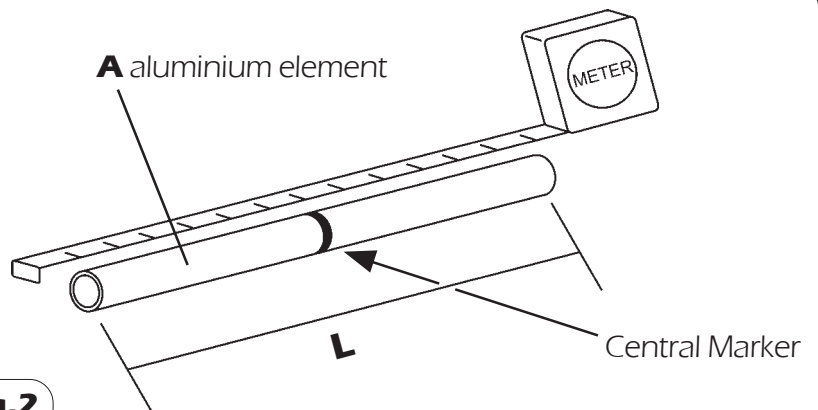

| Part List |   |
|-----------|---|
| Q.ty      | Description                                     |
| 3         | <b>A</b> ) Aluminium tubes (3 different length) |
| 6         | <b>C</b> ) M5x6 Hexagon socket set screw        |
| 1         | <b>D</b> ) 2.5mm Hexagonal key                  |
| 6         | <b>E</b> ) Plastic cap                          |

# MOUNTING INSTRUCTIONS

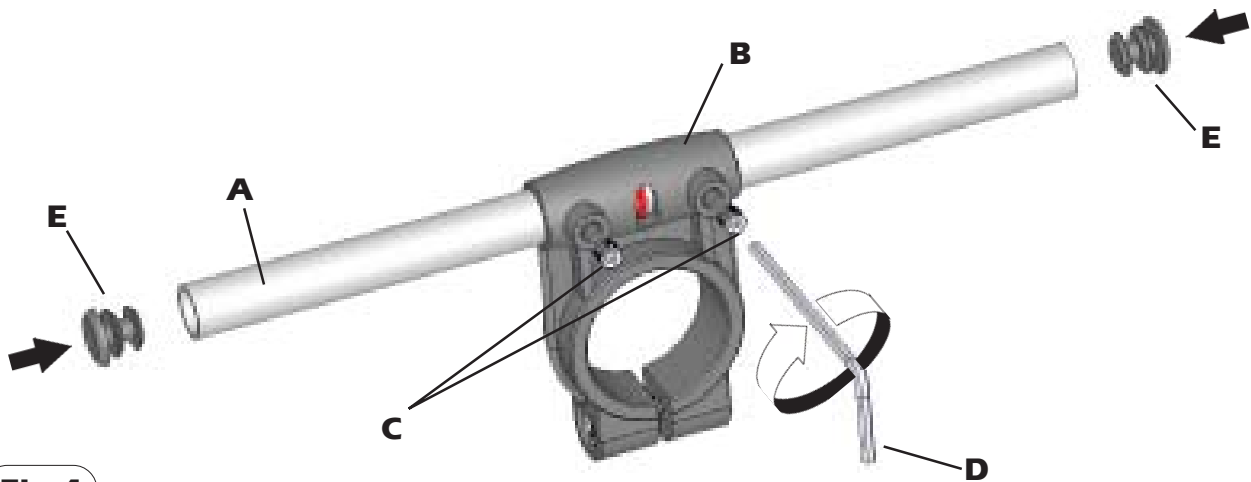

**Fig.4**

## Dipole mounting

- 1) Place the O-ring gasket **F** on the dipole connector **G**. (See **Fig.5**)
  - 2) Insert the antenna's dipole **H** in the dipole connector **G**
  - 3) Fix the antenna's dipole **H** by using the plastic fixing clamp **I** and the screws **J**. Lock the screws to well fix the plastic parts to avoid any gap (see **Fig.6**)
- Remark: the antenna's dipole must be aligned to the elements tubes **A**.*

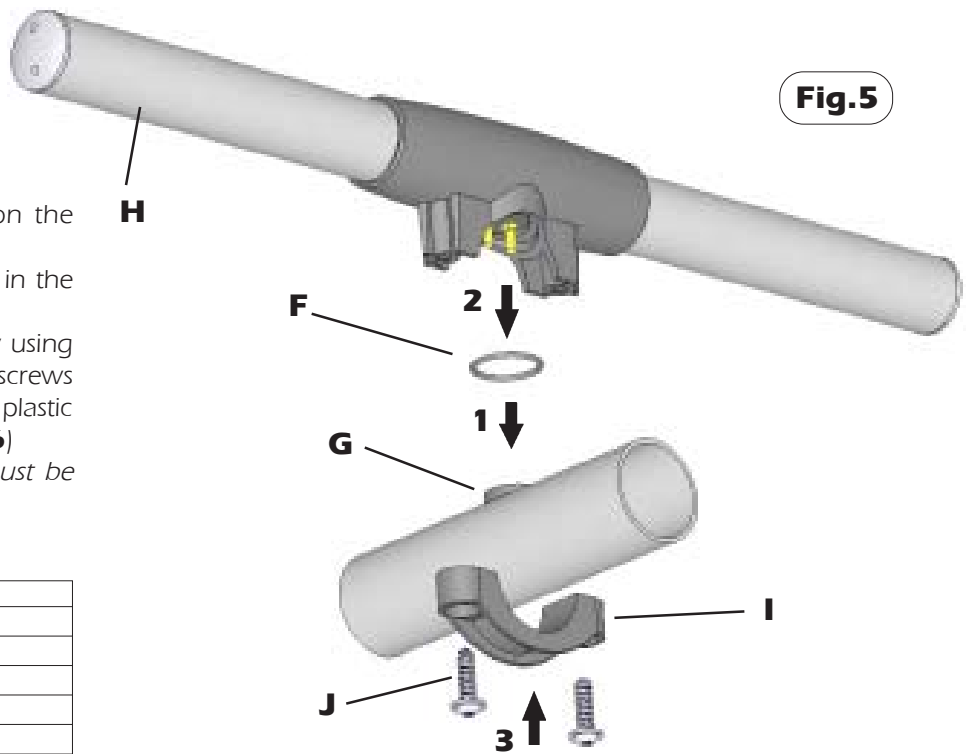

**Fig.5**

| Part List |                                       |
|-----------|---------------------------------------|
| Q.ty      | Description                           |
| 1         | <b>F</b> ) O-ring gasket              |
| 1         | <b>H</b> ) Antenna's dipole           |
| 1         | <b>I</b> ) Plastic fixing clamp       |
| 2         | <b>J</b> ) Tapping Screws for plastic |

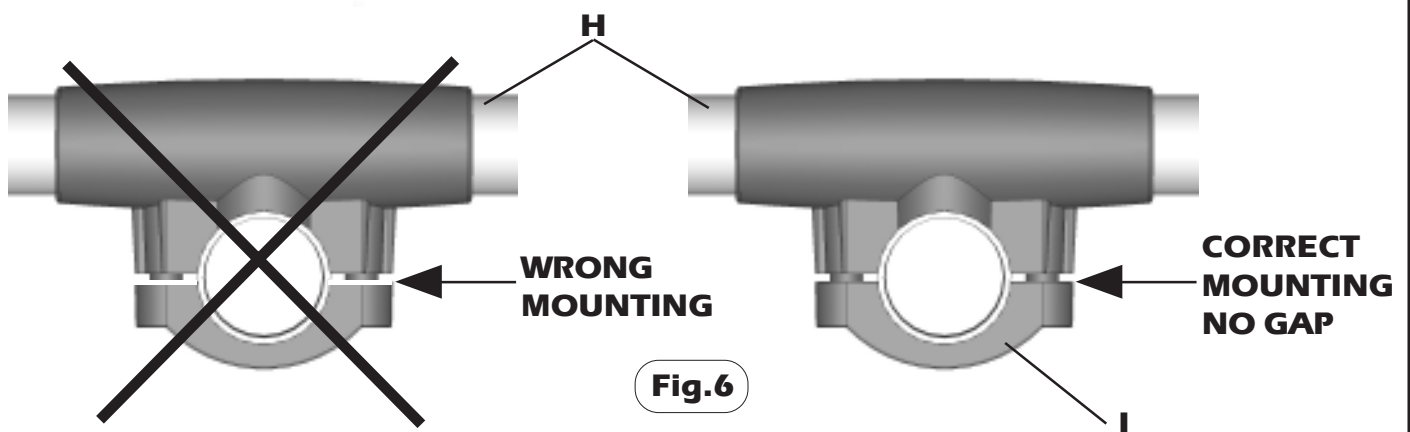

**Fig.6**

# MOUNTING INSTRUCTIONS

## Standard Mounting Bracket

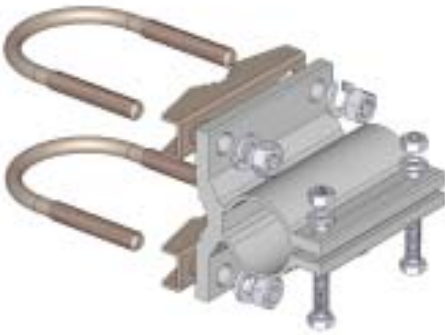

### Spare parts: p/n SA197

Materials: extruded aluminum  
Hardware: stainless & zinc plated steel  
Dimensions : 80 x 76 x 65 mm  
Weight: 460 gr

| Part List |                            |
|-----------|----------------------------|
| Q.ty      | Description                |
| 1         | Extruded aluminium bracket |
| 2         | Steel bracket              |
| 2         | M8x200 U-bolt              |
| 4         | M8 Grower washer           |
| 4         | M8 Hexagonal nut           |
| 2         | M6x20 Hexagonal head screw |
| 2         | M6 Grower washer           |
| 2         | M6 Hexagonal nut           |

## Tilting Bracket\*



### Order p/n: 2519803.00

Materials & Hardware: zinc plated steel  
Dimensions: 110 x 150 x 6 mm.  
Weight: 800 gr

| Part List |                           |
|-----------|---------------------------|
| Q.ty      | Description               |
| 1         | 110x150x6 Tilting bracket |
| 4         | M8x25 Spheric head screw  |
| 4         | M8 Grower washer          |
| 4         | M8 Hexagonal nut          |

## Mounting example

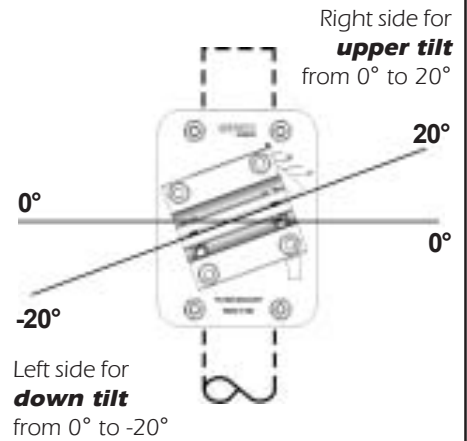

\* **Optional (not included).**

## Connector protection cap

Spare parts: p/n TE06416

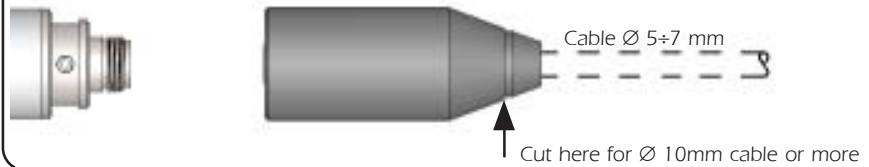

## Stacking and Baying distance

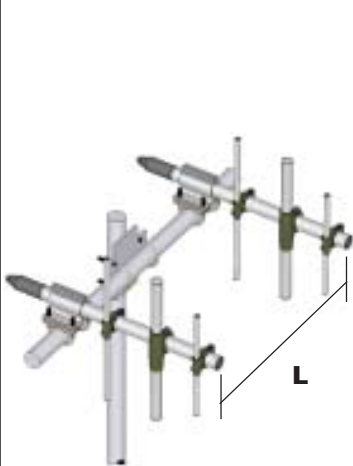

Vertical polarization  
(Bayed)  
**L = 1.1 m**

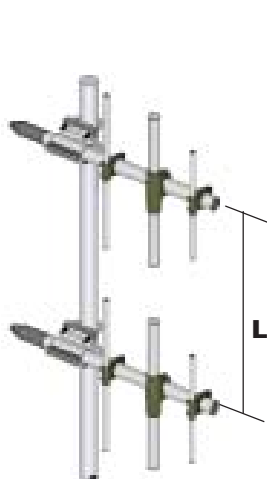

Vertical polarization  
(Stacked)  
**L = 1.6 m**

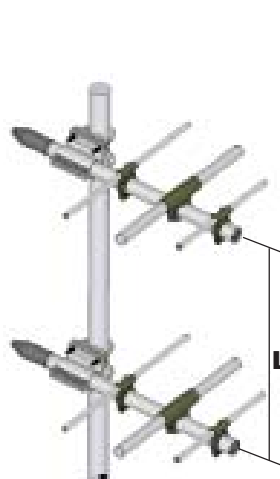

Horizontal polarization  
(Stacked)  
**L = 1.1 m**

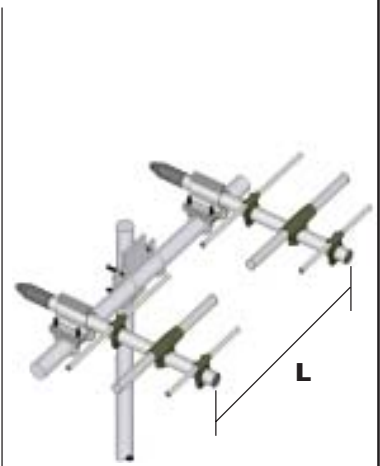

Horizontal polarization  
(Bayed)  
**L = 1.6 m**

# WY155-4N

## 155-175 MHz Base Station 4 Element Yagi Antenna

### DESCRIPTION

Base station antenna conceived by using an innovative feed system studied and applied to have highly symmetrical radiation pattern in both planes (E and H). It's completely computer designed to get high performances of gain and front-to-back in the working band. All aluminium parts are protected by anodized treatment, hardware are of Stainless steel or zinc plated steel, mounting bracket is of extruded aluminium for the best strength and the connector is placed in rear position for an easily access. To increase the antenna gain please install it in stacked or bayed array. **Patent pending applied.**

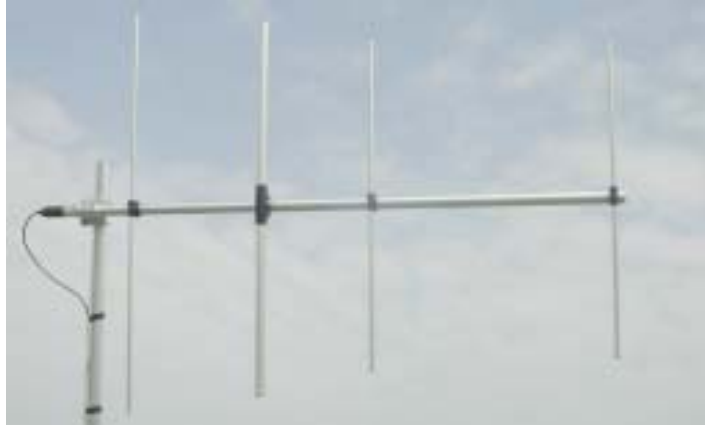

### TECHNICAL DATA

#### Electrical Data

|                        |  |
|------------------------|--|
| Type                   | 4 elements Yagi                            |
| Frequency range        | 155 - 175 MHz                              |
| Impedance              | 50 $\Omega$ Unbalanced                     |
| Polarization           | Linear Vertical or Horizontal              |
| Radiation (H-plane)    | beamwidth at -3 dB= 100° at 165 MHz        |
| Radiation (E-plane)    | beamwidth at -3 dB= 65° at 165 MHz         |
| Max Gain               | 8.5 dBi                                    |
| Front to Back ratio    | $\geq 16$ dB                               |
| S.W.R. in bandwidth    | $\leq 1.5:1$                               |
| Max Power              | 200 Watts (CW) at 30°C                     |
| Feed system / Position | RG303 Teflon coax with balun / inside boom |
| Lightning protection   | DC-ground                                  |
| Connector              | N-female with rubber protection cap        |

#### Mechanical Data

|                        |   |
|------------------------|---|
| Materials              | Anodized 6063-T5 Aluminium,<br>Thermoplastic UV stabilized, Chromed Brass |
| Wind load / resistance | 141 N at 150 Km/h / 140 Km/h  |
| Wind surface           | 0.114 m <sup>2</sup>  |
| Dimensions (approx.)   | 1600 x 985 mm   |
| Weight (approx.)       | 2015 gr   |
| Turning radius         | 1530 mm   |
| Operating temperature  | -40° C to +60° C  |
| Mounting Mast          | $\varnothing$ 35-52 mm  |

TYPICAL RADIATION PATTERN at 165 MHz

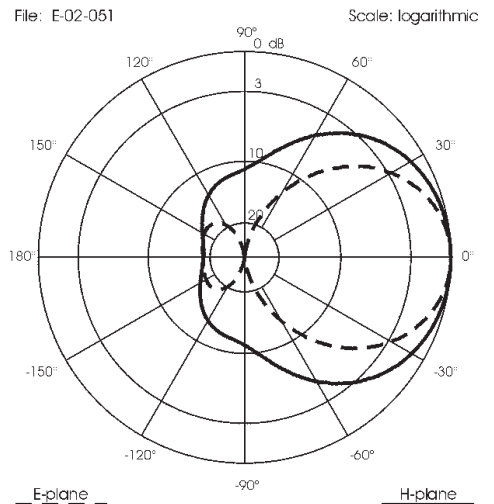

TYPICAL GAIN DIAGRAM vs FREQUENCY

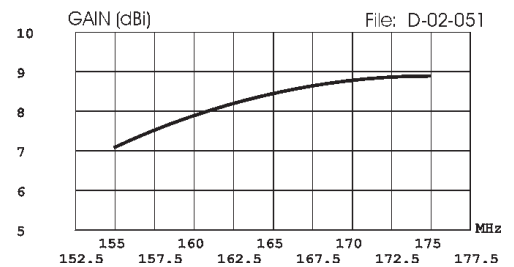

TYPICAL S.W.R. RESPONSE

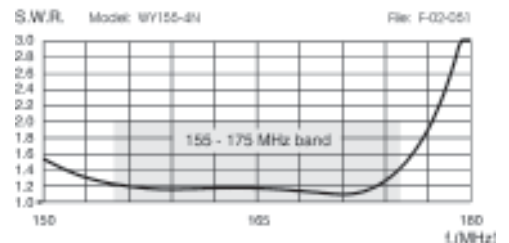

# MOUNTING INSTRUCTIONS

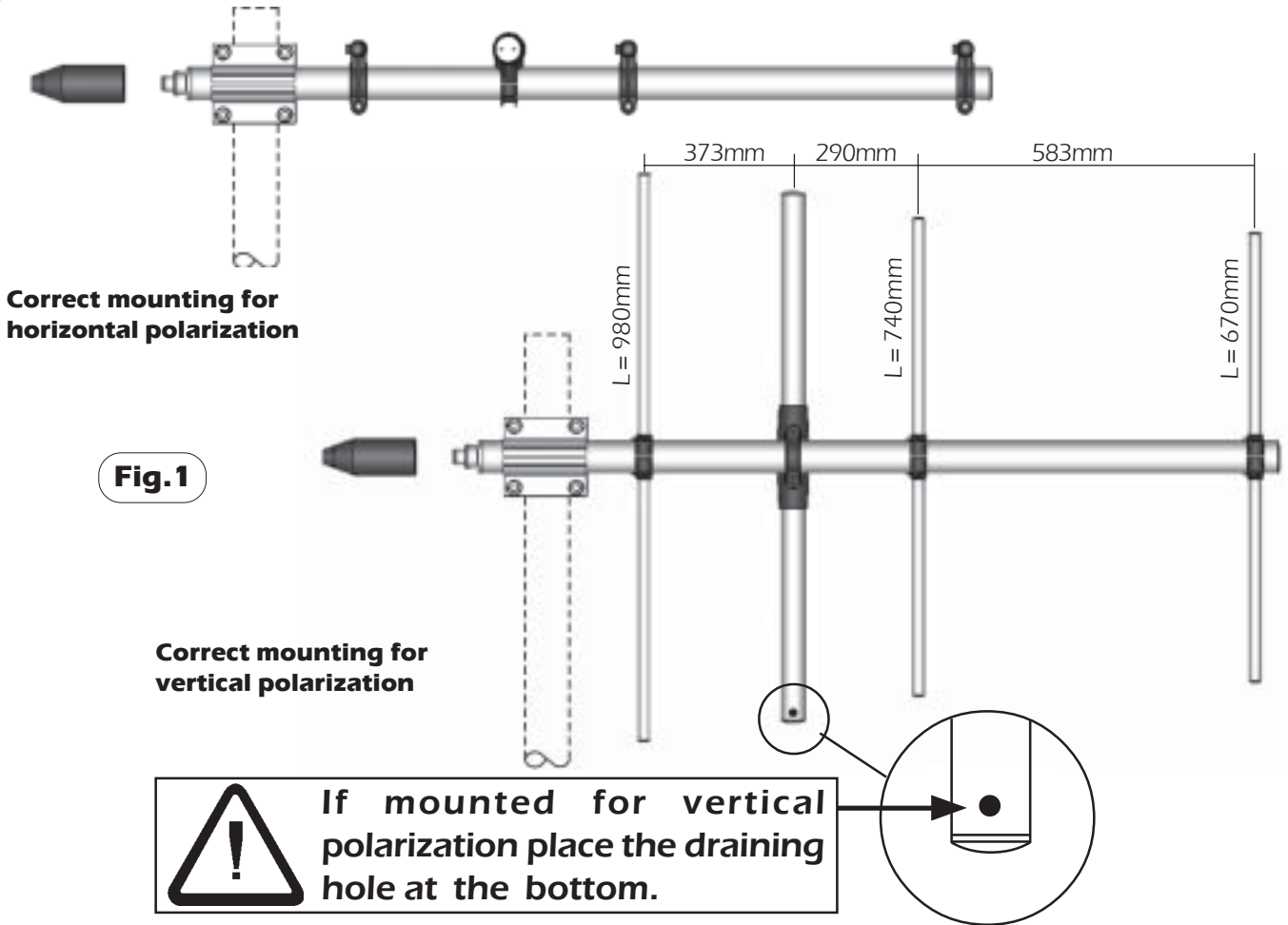

## Element Mounting

1) By means of a meter measure the aluminium elements **A** and position them in the plastic support **B** of the boom according to **fig. 1**.

2) Place the reference marker of the aluminium element **A** in the centre of the plastic support **B** (see **fig. 3**) and lock the screws **C** by the supplied key **D** (**fig. 4**). When the screws touch the aluminium tubes you can finally lock them turning for 1.5 turns.

**Warning: do not exceed 1.5 turns. The plastic support threads could be damaged.**

3) Insert the plastic caps **E** on the aluminium elements **A** (see **fig. 4**)

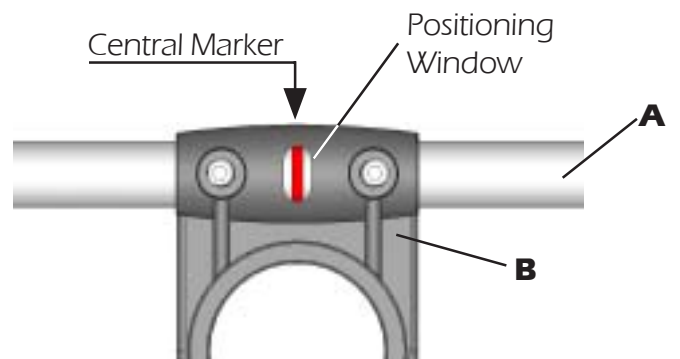
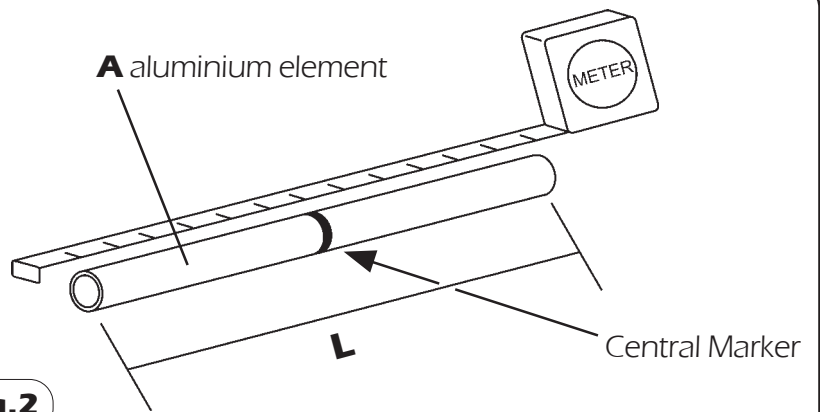

| Part List |   |
|-----------|---|
| Q.ty      | Description                                     |
| 3         | <b>A</b> ) Aluminium tubes (3 different length) |
| 6         | <b>C</b> ) M5x6 Hexagon socket set screw        |
| 1         | <b>D</b> ) 2.5mm Hexagonal key                  |
| 6         | <b>E</b> ) Plastic cap                          |

# MOUNTING INSTRUCTIONS

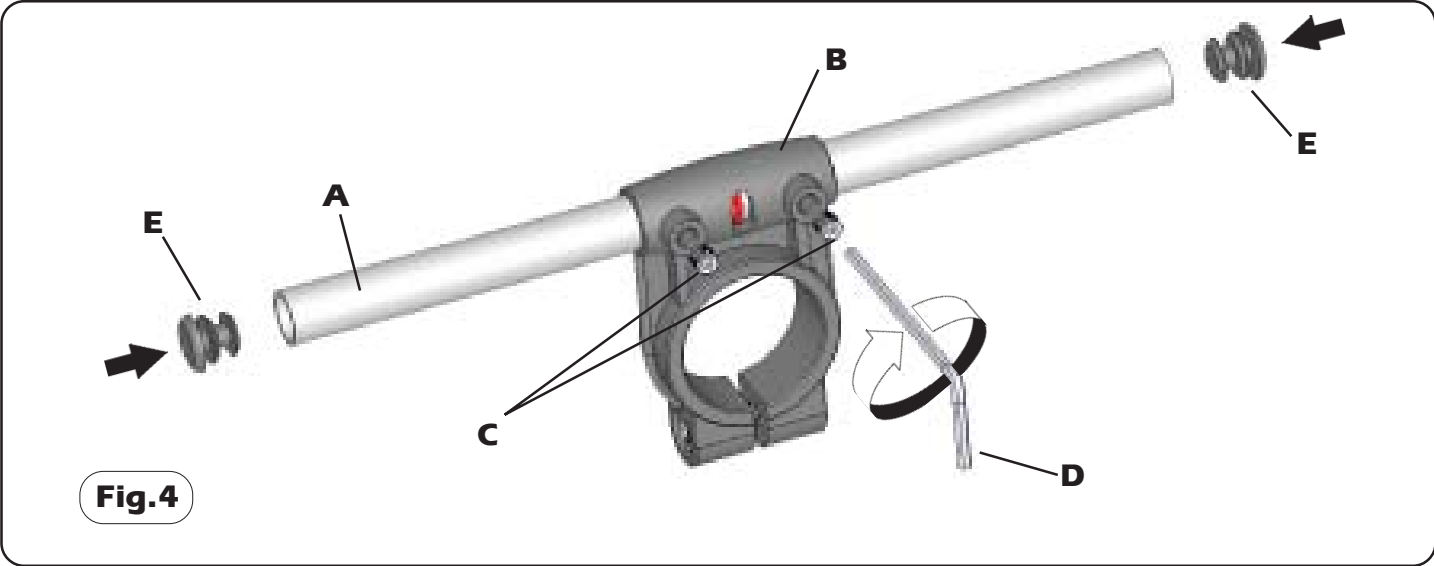

**Fig.4**

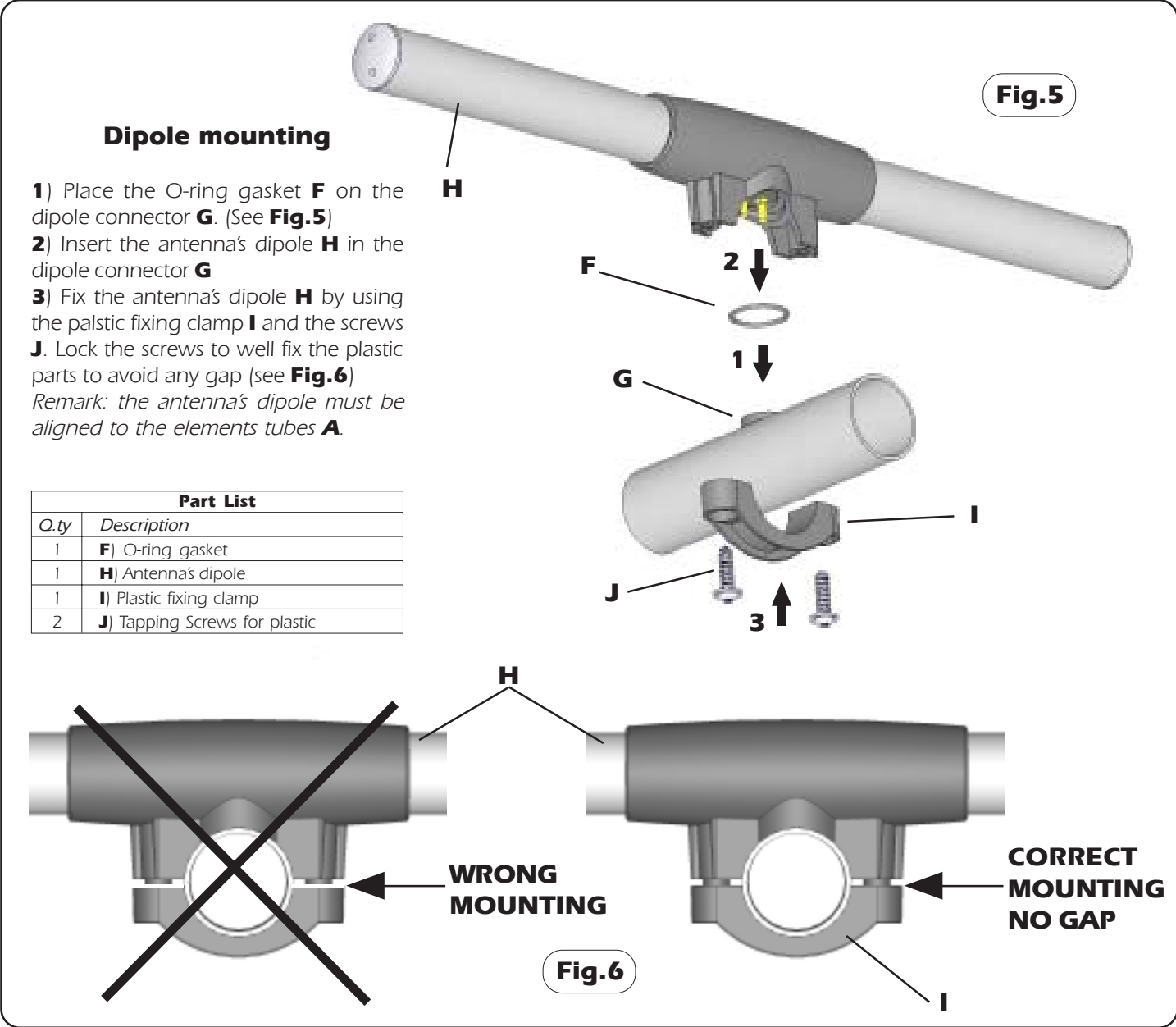

**Fig.6**