

MOUNTING INSTRUCTIONS

SD/SY Mounting Bracket

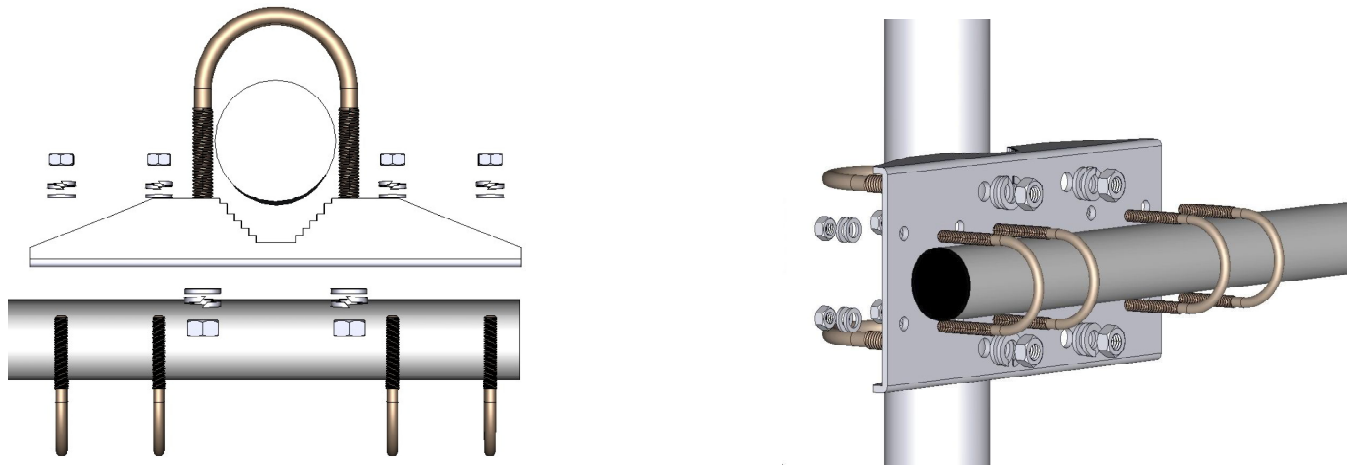

SD/SY bracket parts list	
Q.ty	Description
1	SD/SY Steel bracket
2	M8x200 U-bolt
4	M8 Hexagonal nut
4	M8 Grower washer
4	M8 Flat Washer
4	M6x125 U-bolt
8	M6 Hexagonal nut
8	M6 Grower washer
8	M6 Flat washer
Materials	Zinc Plated Steel
Weight	865g
Re-order code: SA088	

Array distance

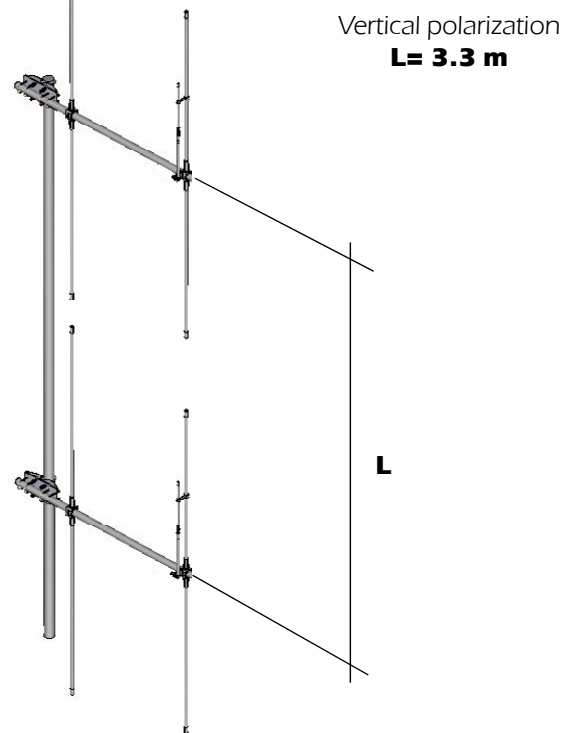

Vertical polarization
L= 3.3 m

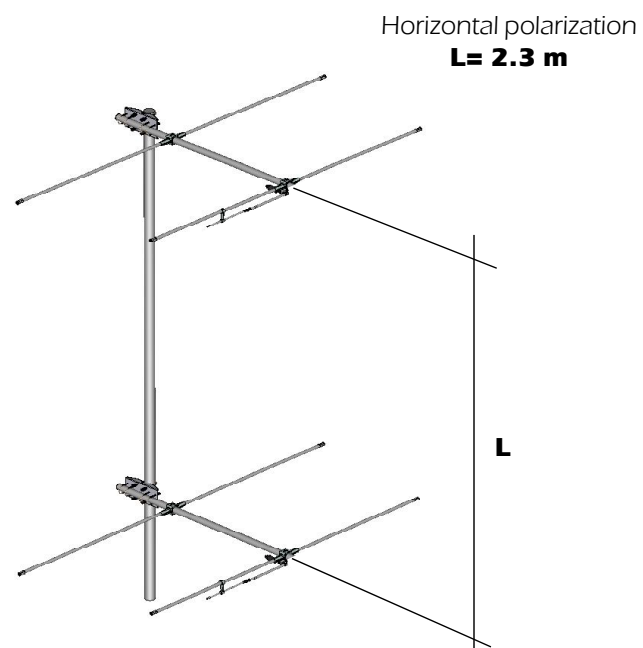

Horizontal polarization
L= 2.3 m

SY68-2

VHF 68-78 MHz Base Station 2 Element Yagi Antenna

DESCRIPTION

Directional 2 elements Yagi antenna for VHF 68-78 MHz with gamma match feed system.

Elements and boom of generous section are completely made of anticorodal aluminum, and the steel bracket is placed in the rear position for the best performance in vertical and horizontal polarization. The elements are fixed to the boom by a strong die-cast metal support to get the maximum strength.

All connections are waterproof and it is supplied whit UHF female connector.

All metal parts and hardware are weather resistant.

To improve the antenna gain please install it in stacked or bayed array.



TECHNICAL DATA

Electrical Data

Type	2 elements Yagi
Frequency range	68 - 78 MHz
Impedance	50 Ω Unbalanced
Polarization	Linear Vertical or Horizontal
Radiation (H-plane)	beamwidth @ -3 dB= 180° @ 73 MHz
Radiation (E-plane)	beamwidth @ -3 dB= 75° @ 73 MHz
Max Gain	5 dBi
Front to Back ratio	\geq 8 dB
SWR in bandwidth	\leq 1.5
Max Power	350 Watts (CW) @ 30°C
Feed system	Gamma Match
Connector	UHF-female with rubber protection cap

Mechanical Data

Materials	Aluminum, EPDM rubber, Zamak, Zinc plated Steel, Chromed Brass
Wind load / resistance	159 N at 150 Km/h / 140Km/h
Wind surface	0.128 m ²
Boom/elements diameter	33mm/16mm
Dimensions (approx.)	1250 x 2235 mm
Weight (approx.)	2695 gr
Turning radius	1562 mm
Operating temperature	-40° C to +80° C
Mounting Mast	\varnothing 35-52 mm

TYPICAL RADIATION PATTERN at 73 MHz
File: E-02-054 Scale: logarithmic

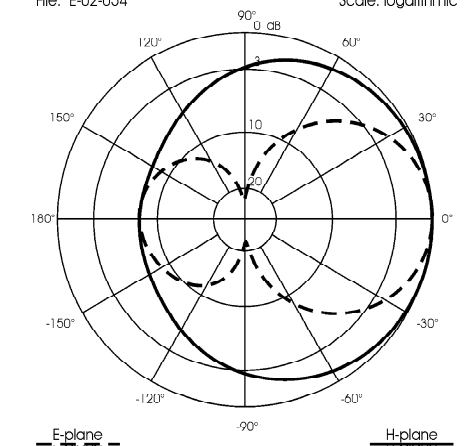

TYPICAL GAIN DIAGRAM vs FREQUENCY
File: D-02-054

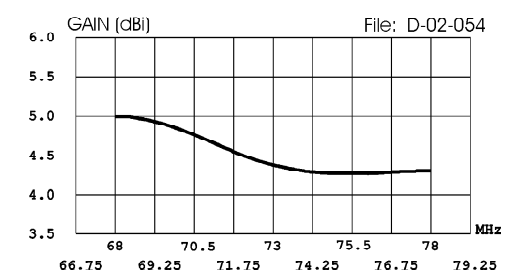

TYPICAL S.W.R. RESPONSE
File: F-02-054

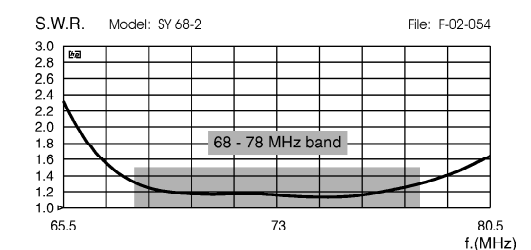

MOUNTING INSTRUCTIONS

Correct mounting for horizontal polarization

Pic.1

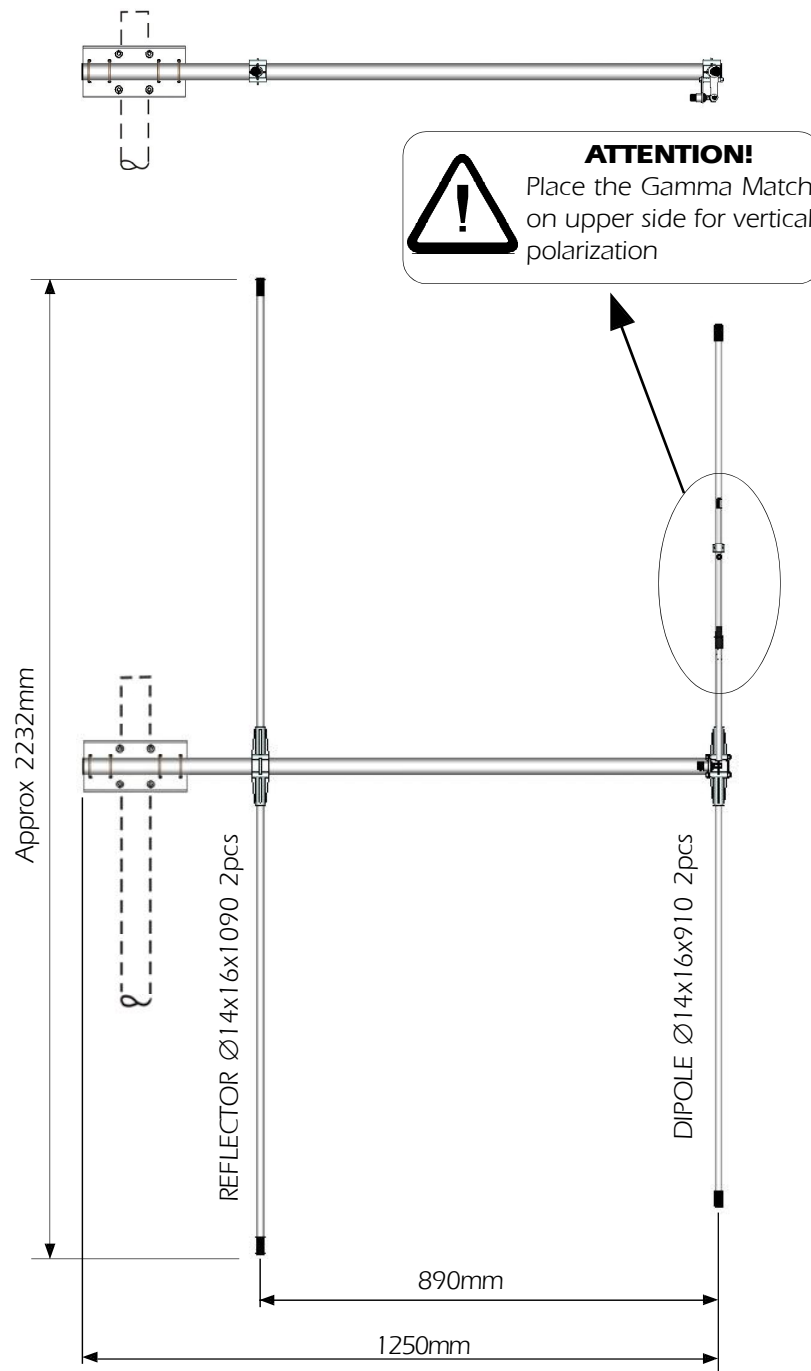

Correct mounting for vertical polarization

Elements Mounting

Measure the length of the aluminum elements by means of a meter and install them in the element support of the boom according to **Pic.1**. Finally fix the elements with supplied screws and key (see **Pic.2**). Be careful to check that all parts are well locked.

Fixing elements hardware parts list

Q.ty	Description
8	M6x6 Hexagon socket set screws
1	3mm Hexagonal key
4	Ø 16mm PVC caps

Re-order code: SA208

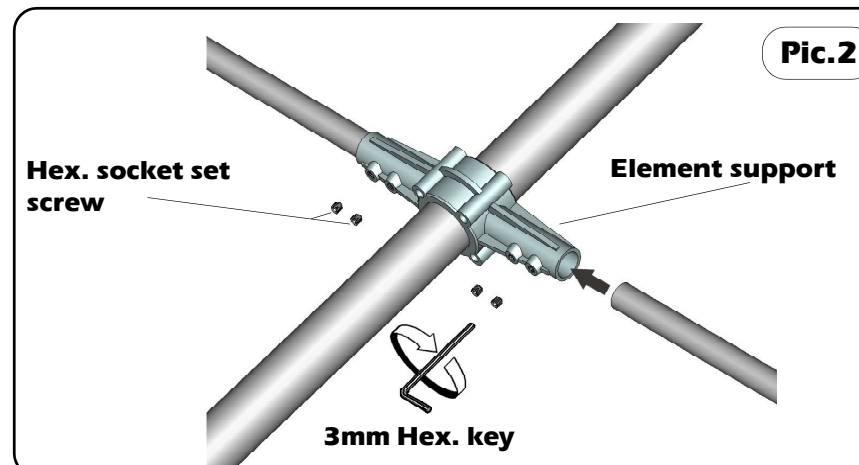

Pic.2

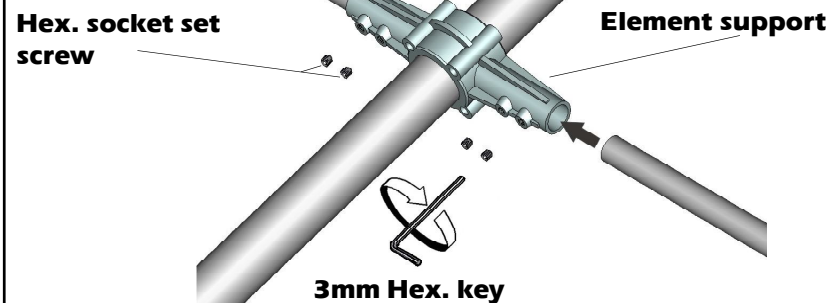

Hex. socket set screw

Element support

3mm Hex. key

MOUNTING INSTRUCTIONS

Gamma-match Mounting

- 1) Fix without locking the flat end of the gamma-match by using the supplied nut and washer according to **pic. 3**
- 2) Insert the tuning element on the dipole tube and move it toward the boom. Insert the opposite side (Ø8) of gamma match in the tuning element and fix it at 356mm by means of the enclosed hardware (see **pic. 4**). Mount the PVC caps Ø16mm on the elements.
- 3) Check that the last part of your gamma match (Ø8mm) is correctly positioned at 58mm according to **L1 (pic. 4)** and fix it with hardware.
- 4) Lock the nut on the flat end of the gamma match and mount the PVC cap (see **pic. 4**)

Gamma Match parts list	
Q.ty	Description
1	Assembled Gamma Match
2	M6x6 Hexagon socket set screws
1	3mm Hexagonal key
1	Ø8 PVC cap
2	M6 Flat washer
1	M6 Grover washer
1	M6 Hexagonal nut
1	Tuning element

Re-order code: SA209

Pic.3

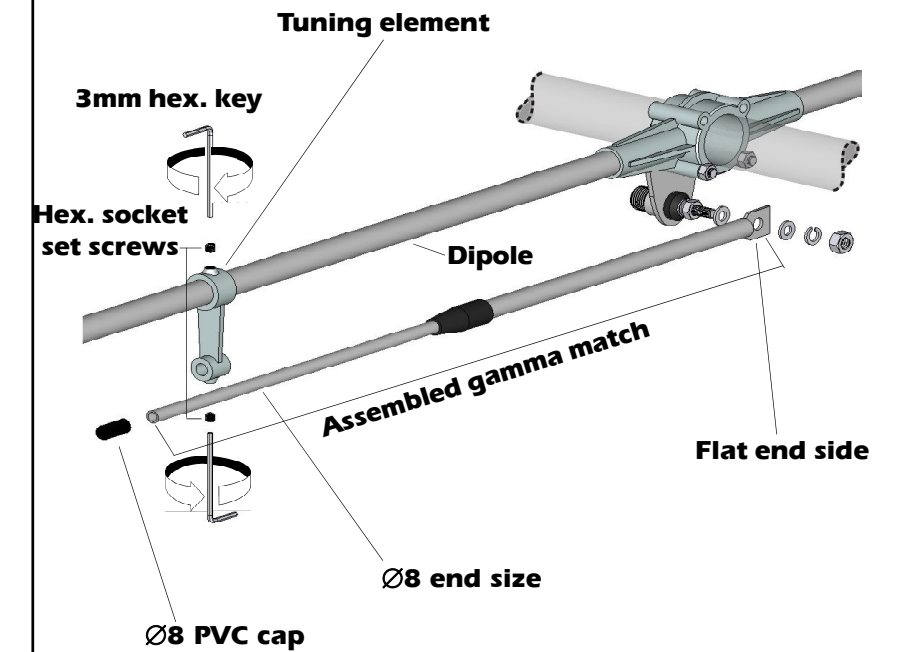

Tuning element

3mm hex. key

Hex. socket set screws

Dipole

Assembled gamma match

Flat end side

Ø8 PVC cap

Ø8 end size

Pic.4

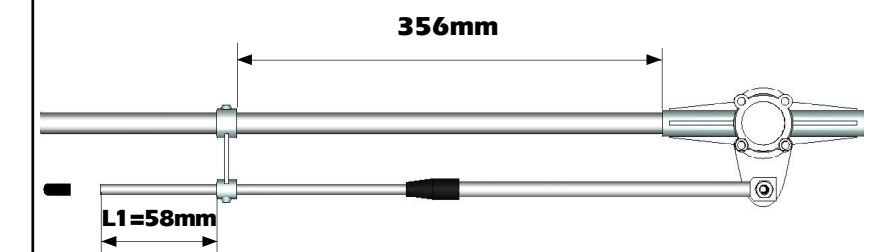

356mm

L1=58mm

Cable connection

