

INSTALLATION & OPERATION MANUAL



MIRAGE™ Beacon

Contents:

- Introduction.....2
- Features and Specifications.....2
- Flash Patterns.....3
- Dimensions.....4
- Installation & Mounting.....4-5
- Wiring.....6
- Operation.....6
- Maintenance.....7
- Troubleshooting.....7
- Warranty.....8

IMPORTANT: Read all instructions and warnings before installing and using.
INSTALLER: This manual must be delivered to the end user of this equipment.

Introduction

The MIRAGE™ Beacon is a weatherproof LED based warning light that contains state-of-the-art high intensity LEDs. The beacon's unique design efficiently captures light from LEDs with individual optics that diffuse the light in an effective warning pattern.

WARNING!



This Product contains high intensity LED devices. To prevent eye damage, DO NOT stare into light beam at close range.



WARNING!

The use of this or any warning device does not insure that all drivers can or will observe or react to an emergency warning signal. Never take the right-of-way for granted. It is your responsibility to be sure you can proceed safely before entering an intersection, driving against traffic, responding at a high rate of speed, or walking on or around traffic lanes.

The effectiveness of this warning device is highly dependent upon correct mounting and wiring. Read and follow the manufacturer's instructions before installing or using this device. The vehicle operator should insure daily that all features of the device operate correctly. In use, the vehicle operator should insure the projection of the warning signal is not blocked by vehicle components (i.e.: open trunks or compartment doors), people, vehicles, or other obstructions. This equipment is intended for use by authorized personnel only. It is the user's responsibility to understand and obey all laws regarding emergency warning devices. The user should check all applicable city, state and federal laws and regulations.

Code 3, Inc., assumes no liability for any loss resulting from the use of this warning device.

Proper installation is vital to the performance of this warning device and the safe operation of the emergency vehicle. It is important to recognize that the operator of the emergency vehicle is under psychological and physiological stress caused by the emergency situation. The warning device should be installed in such a manner as to: A) Not reduce the output performance of the system, B) Place the controls within convenient reach of the operator so that he can operate the system without losing eye contact with the roadway.

Emergency warning devices often require high electrical voltages and/or currents. Properly protect and use caution around live electrical connections. Grounding or shorting of electrical connections can cause high current arcing, which can cause personal injury and/or severe vehicle damage, including fire.

PROPER INSTALLATION COMBINED WITH OPERATOR TRAINING IN THE PROPER USE OF EMERGENCY WARNING DEVICES IS ESSENTIAL TO INSURE THE SAFETY OF EMERGENCY PERSONNEL AND THE PUBLIC.

Features and Specifications:

Operating Voltage: DC11V-16V, Reverse Polarity Protected

Operating Current: Avg 1.5 amps, Max 3.0 amps

Weight: 1.1 lb

Flash Modes Description:

- | | |
|--------------------------|--|
| 1. Cycle-Flash: | Cycles through Quad, Double, Triple, and Single modes. |
| 2. Quad-Flash: | Four consecutive pulses per flash. |
| 3. Triple-Flash: | Three consecutive pulses per flash. |
| 4. Double-Flash: | Two consecutive pulses per flash. |
| 5. Single-Flash: | Single pulse per flash. |
| 6. Variable Single-Flash | Single pulse per flash with varying flash rate. |

Please note that a beacon set with a PHASE 0 flash pattern will alternate with beacons set with a PHASE 1 pattern and flash simultaneously with beacons set with a PHASE 0 flash pattern.

Flash Patterns:

PATTERN NO.	PATTERNS	SYNCHRONIZE
1	Cycle Flash 75fpm Phase 0	YES
2	NFPA Quad Phase 0	YES
3	Quad 75fpm Phase 0	YES
4	Triple 75fpm Phase 0	YES
5	Double 75fpm Phase 0	YES
6	Single 75fpm Phase 0	YES
7	Variable Single Flash Phase 0	YES
8	Rotate 75rpm	Simultaneous Only
9	Cycle Flash 75fpm Phase 1	YES
10	NFPA Quad Phase 1	YES
11	Quad 75fpm Phase 1	YES
12	Triple 75fpm Phase 1	YES
13	Double 75fpm Phase 1	YES
14	Single 75fpm Phase 1	YES
15	Variable Single Flash Phase 1	YES
16	Cycle Flash 150fpm Phase 0	YES
17	Quad 150fpm Phase 0	YES
18	Triple 150fpm Phase 0	YES
19	Double 150fpm Phase 0	YES
20	Single 150fpm Phase 0	YES
21	Single 250fpm Phase 0	YES
22	Single 375fpm Phase 0	YES
23	Rotate 150rpm	Simultaneous Only
24	Cycle Flash 150fpm Phase 1	YES
25	Quad 150fpm Phase 1	YES
26	Triple 150fpm Phase 1	YES
27	Double 150fpm Phase 1	YES
28	Single 150fpm Phase 1	YES
29	Single 250fpm Phase 1	YES
30	Single 375fpm Phase 1	YES

Flash Patterns for ECE-65 compliant beacons:

PATTERN NO.	PATTERNS	SYNCHRONIZE
1	Single Flash 120fpm	Simultaneous Only
2	Double Flash 120fpm	Simultaneous Only
3	Triple Flash 120fpm	Simultaneous Only
4	Quad Flash 120fpm	Simultaneous Only
5	Quintuple Flash 120fpm	Simultaneous Only
6	Rotating 120rpm	Simultaneous Only

Dimensions:

(Basic dimensions are as shown)

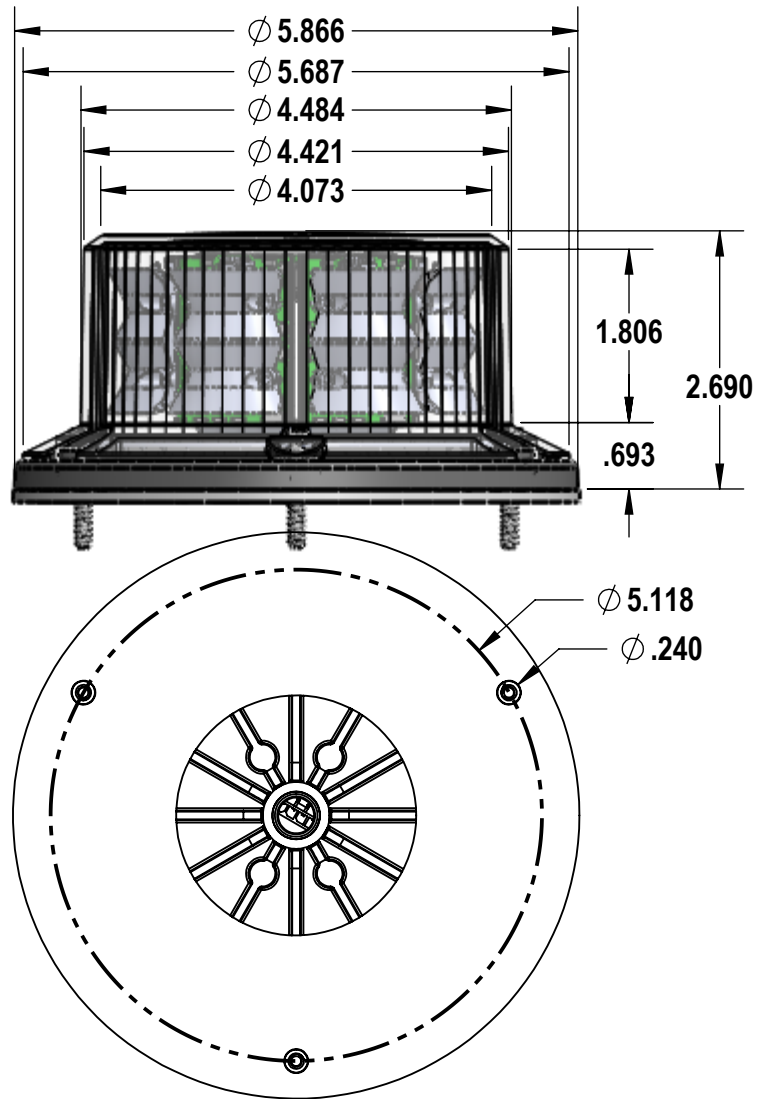

Standard Mounting Procedure:

1. Use the beacon base to locate holes on mounting surface. Holes should accommodate a #8 fastener. A hole should be provided for wiring access at the center of the mounting area. The hole should be grommeted and sealed with RTV around the wiring.
2. Place gasket and beacon assembly on mounting surface being careful to align the mounting holes. Care should be taken to not pinch the wiring when placing the beacon assembly.
3. Install three #8 fasteners provided by the user as shown to attach the assembly.

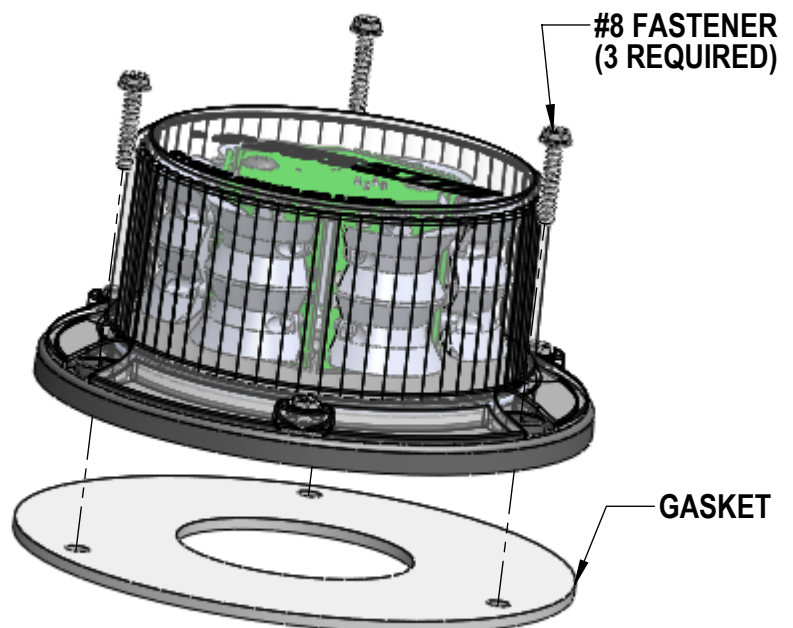

M6 Mounting Procedure:

1. Use the beacon base to locate holes on mounting surface. Holes should accommodate a #M6 fastener and are arranged in a 130mm circular pattern. A hole should be provided for wiring access at the center of the mounting area. The hole should be grommeted and sealed with RTV around the wiring.
2. Place gasket and beacon assembly on mounting surface being careful to align the mounting holes. Care should be taken to not pinch the wiring when placing the beacon assembly.
3. Install three M6 fasteners provided by the user as shown to attach the assembly. The base accepts M6 hex head fasteners and will prevent rotation while the mating nuts are installed.

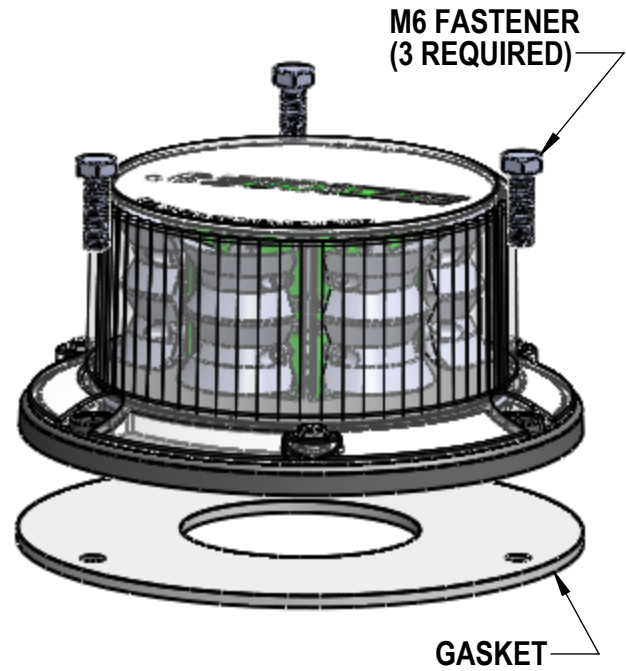

Magnetic Mounting Procedure:



As with any magnetically-mounted warning device, its use on the exterior of a moving vehicle is at the sole discretion and responsibility of the user. This magnetic mount product provides a secure, temporary installation in most circumstances and is recommended for stationary use only.

The magnetic mount beacon is equipped with a two wire cord that terminates in an electrical plug with rocker switch. For electrical connection the plug is inserted into a 12 Volt DC cigarette lighter outlet by pushing and rotating with reasonable moderate force to insure the best possible connection.

The magnetic based beacon provides a secure, temporary installation. The beacon should be placed in the center of the roof where the least amount of curvature occurs. Check the magnet for debris before installation. Any foreign matter can reduce holding power and scratch the vehicle. The roof surface should be dry and have a dull, not glossy finish. A glossy, highly waxed surface will reduce the magnet's holding power. When placed, the beacon should adhere firmly.

The user should not attempt to drive with the beacon in place should the unit slide or move easily.

Wiring Instructions Permanent Mount:

The beacon is terminated with a 6" long 6-wire cable harness that may be connected as follows:

<u>COLOR</u>	<u>FUNCTION</u>	<u>CONNECT TO</u>
Red	Power	+VDC
Black	Ground	Chassis ground
White	Pattern Switching	Chassis ground to activate
Yellow	Synchronization	See synchronization below
Green	not used	not used
Violet	Dim	+VDC to activate

Operation:

Synchronization (Permanent Mount Only):

To synchronize multiple beacons, configure as noted below. A maximum of 8 lights may be synchronized.

- To configure the beacons to flash their patterns simultaneously, advance the pattern for each beacon to Phase 0 mode of the chosen pattern. Connect the YELLOW wires from each beacon together. When the beacons are activated, their patterns will flash together.
- To configure the beacons to alternate their patterns, advance the pattern of either beacon (but not both) to the Phase 1 mode of the chosen pattern.

Setting the Flash Pattern (Permanent Mount):

Momentarily connect the WHITE wire to chassis ground as follows:

- For the NEXT pattern; release contact when beacon flashes ON (less than 2 seconds)
- For the PREVIOUS pattern; release contact when beacon flashes ON then OFF (2 to 4 seconds)
- For the DEFAULT pattern; release contact when beacon flashes ON then OFF then ON again (greater than 4 seconds)

Setting the Flash Pattern (Magnetic base):

Remove the outer lens to access the top of the beacon control board.

With the power on, short across momentarily (make electrical contact between) the bare copper pads near the center of the board as follows:

- For the NEXT pattern; release contact when beacon flashes ON (less than 2 seconds)
- For the PREVIOUS pattern; release contact when beacon flashes ON then OFF (2 to 4 seconds)
- For the DEFAULT pattern; release contact when beacon flashes ON then OFF then ON again (greater than 4 seconds)

Maintenance:

The beacons are designed to be maintenance free. Refer to the guide below for help with troubleshooting. Should the unit be diagnosed as malfunctioning, remove unit and replace with a new beacon.

WARNING!



LED beacon housings may become hot with extended use. Allow beacons to cool completely before attempting to remove.

TROUBLESHOOTING		
Problem	Probable Cause	Remedy
Beacon does not activate	a. No power to unit	a. Check wire for loose connection
	b. Power input wire reversed	b. Reverse power wires
	c. Damaged or shortaged cabling	c. Check cables for damage
	d. Defective beacon	d. Replace beacon module
Beacon is constantly ON	a. Control wire permanently grounded or shorted to GND	a. Avoid permanent grounding of control wire

WARRANTY

Code 3, Inc.'s L.E.D. emergency devices are tested and found to be operational at the time of manufacture. Provided they are installed and operated in accordance with manufacturer's recommendations, Code 3, Inc. guarantees all parts and components except the lamps to a period of 1 year, LED Lighthouse modules to a period of 5 years (unless otherwise expressed) from the date of purchase or delivery, whichever is later. Units demonstrated to be defective within the warranty period will be repaired or replaced at the factory service center at no cost.

Use of lamp or other electrical load of a wattage higher than installed or recommended by the factory, or use of inappropriate or inadequate wiring or circuit protection causes this warranty to become void. Failure or destruction of the product resulting from abuse or unusual use and/or accidents is not covered by this warranty. Code 3, Inc. shall in no way be liable for other damages including consequential, indirect or special damages whether loss is due to negligence or breach of warranty.

CODE 3, INC. MAKES NO OTHER EXPRESS OR IMPLIED WARRANTY INCLUDING, WITHOUT LIMITATION, WARRANTIES OF FITNESS OR MERCHANTABILITY, WITH RESPECT TO THIS PRODUCT.

PRODUCT RETURNS

If a product must be returned for repair or replacement*, please contact our factory to obtain a Return Goods Authorization Number (RGA number) before you ship the product to Code 3, Inc. Write the RGA number clearly on the package near the mailing label. Be sure you use sufficient packing materials to avoid damage to the product being returned while in transit.

*Code 3, Inc. reserves the right to repair or replace at its discretion. Code 3, Inc. assumes no responsibility or liability for expenses incurred for the removal and/or reinstallation of products requiring service and/or repair; nor for the packaging, handling, and shipping; nor for the handling of products return to sender after the service has been rendered.

**PROBLEMS OR QUESTIONS? CALL OUR TECHNICAL ASSISTANCE HOTLINE (314) 996-2800
or visit WWW.CODE3PSE.COM, select C3 FORUM and place your question on the forum**



Code 3, Inc.
10986 N. Warson Road
St. Louis, Missouri 63114-2029—USA
Ph. (314) 426-2700 Fax (314) 426-1337
www.code3pse.com