



## INSTRUCTION MANUAL

MULTI-CHARGER  
**BC-121N**

---

---

---

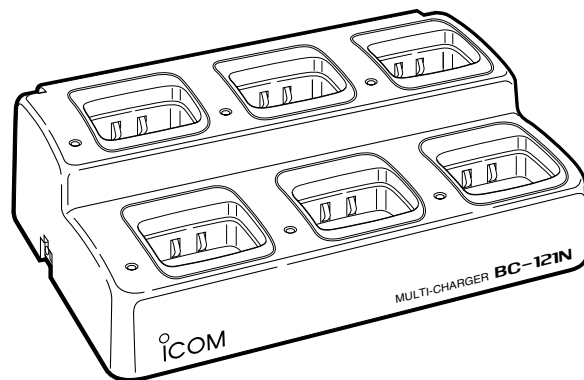

Icom Inc.

---

---

## FOREWORD

---

Thank you for purchasing the Icom BC-121N MULTI-CHARGER. Please read this instruction manual carefully before using the BC-121N.

By installing desktop charger adapters, the BC-121N rapidly charges up to six Ni-Cd or Ni-MH battery packs simultaneously in 1 to 2 hours, or Li-Ion battery pack in 2 to 3 hours.

Appropriate desktop charger adapters **MUST** be purchased separately to charge your Icom battery packs. See your transceiver's instruction manual for desktop charger adapter details.

### Information (USA only)



The Ni-Cd battery that you have purchased is recyclable. At the end of its life, under various state and local laws, it may be illegal to dispose of this battery into the municipal waste stream. Call 1-800-822-8837 for battery recycling options in your area or contact your dealer.



Some versions of the BC-121N which display the "CE" symbol on the serial number comply with the essential requirements of the 89/336/EEC directive for Electromagnetic Compatibility.

This compliance is based upon the harmonised CENELEC generic standard EN50 081-1: 1992 and EN50 082-1: 1991.

---

## CAUTION

---

**SAVE THESE INSTRUCTIONS!** This manual contains important safety and operating instructions for the BC-121N MULTI-CHARGER.

**READ ALL INSTRUCTIONS** thoroughly and carefully before using this multi-charger.

**CAUTION!** To reduce the risk of injury, charge only specified Icom Ni-Cd, Ni-MH and/or Li-Ion rechargeable batteries. Other types of batteries may burst, causing damage and personal injury.

**IN DOOR USE only! NEVER** expose the multi-charger and the AC adapter to rain, snow or any liquids.

**NEVER** let metal, wire, etc., touch any internal parts of the multi-charger.

**NEVER** use the multi-charger with the AC adapter when it is covered by objects which impede heat dispersal.

**NEVER** allow children to touch the multi-charger. Place the charger in a secure place to avoid inadvertent use by them.

**NEVER** use an accessory which Icom does not sell or recommend. Using non-Icom accessories may result in a fire hazard or electric shock.

**NEVER** attempt to charge alkaline or dry cell batteries. They may burst causing damage and personal injury.

**NEVER** incinerate used batteries. This may cause an explosion.

**DO NOT** operate the AC adapter with a damaged cord or plug. Replace immediately.

**DO NOT** operate the multi-charger and/or AC adapter if it has been dropped or damaged in any way. The charger must be inspected by an authorized service center in such cases.

**DO NOT** disassemble the multi-charger and/or AC adapter. Incorrect reassembly may result in a fire hazard or electric shock.

**DO NOT** place liquids on or near the battery charger.

**AVOID** charging in extreme cold (under +10°C; +50°F) or extreme heat (over +40°C; +104°F). Battery packs may not charge fully under extreme temperatures.

**KEEP** the multi-charger away from TV sets or radios to prevent interference.

/// Make sure battery and charger contacts are clean, otherwise batteries may not fully charge.

In order to get the maximum life out of your Ni-Cd batteries:

1. Avoid overcharging—batteries must be removed from the charger to stop charging. Batteries should not be charged for more than 15 hours after the LED indicator turns green.
2. Use the batteries until they become almost completely exhausted under normal conditions.

Be careful of the battery pack's temperature—when the battery pack is extremely cold (especially for Ni-MH batteries), the charger cannot charge the battery.

When the charger is not in use, disconnect the AC adapter from an AC outlet. The AC adapter consumes power when connected to the AC outlet.

When the operating period becomes extremely short after full charging, the battery pack has reached the end of its life and a new battery pack must be purchased.

An appropriate desktop charger adapter must be purchased separately to charge your Icom battery packs.

/// If your batteries seem to have no capacity even after being fully charged, completely discharge them, then fully charge them again. If they still do not retain a charge (or very little), new batteries must be purchased.

#### **BATTERY MEMORY EFFECT**

The full charge capacity of Ni-Cd rechargeable batteries may be reduced if repeatedly charged with only partial discharge periods. This is called the battery memory effect. If the battery capacity seems lower than new, discharge the battery pack (e.g. connect to a transceiver and leave the transceiver's power ON all day) then charge fully again. When the capacity is still low, a new battery must be purchased.

# DESKTOP CHARGER ADAPTERS

Install six appropriate desktop charger adapters into the spaces of the BC-121N. Several adapters are available as described in the table at right to accommodate various Icom portable transceivers.

## ◆ For the PCB types

Connect the plugs of an appropriate desktop charger adapter and the BC-121N, then installed the adapter with the screws (supplied with the adapter).

### • Installing the PCB type adapter

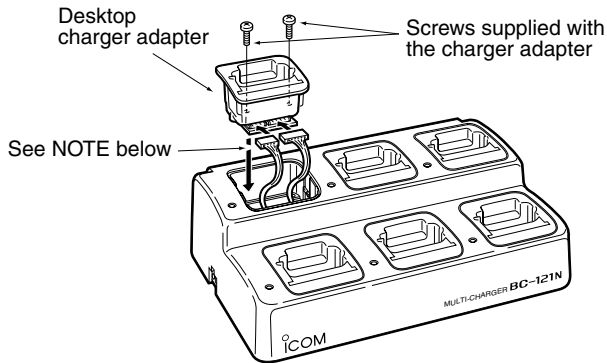

**NOTE:** Some of the PCB type desktop charger adapters do not need connection of the 3-pin connector. The connection is required only for the installing adapter that is compatible with charging a Li-Ion battery pack.

## ◆ For types requiring the AD-75/AD-88

Install the optional AD-75 or AD-88 to the BC-121N with 4 screws (supplied with the AD-75/AD-88), then attach a desktop desktop charger adapter to the BC-121N. See the transceiver's instruction manual for an approved desktop p charger adapter.

### • Installing the AD-75/AD-88

### • Installing the non-PCB type adapter

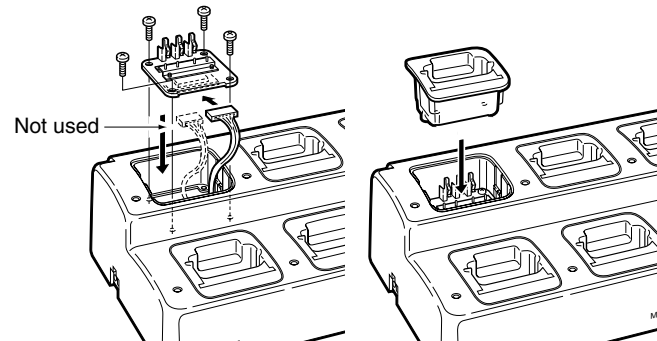

## ⚠ CAUTION

### About the 3-pin connector:

When you replace the desktop charger adapter from the Li-Ion compatible type to non-compatible type, fix the 3-pin connector to the bottom of the charger with adhesive tape, etc., to prevent catching or touching the 3-pin connector's terminals with the adapter's leads, etc.

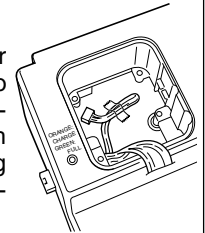

## DESKTOP CHARGER ADAPTERS

### ◆ PCB type adapters

Transceiver	Charger Adapter	Battery pack
IC-F10/F20, IC-M10A/E, IC-2GX series, IC-V68/U68	AD-66	BP-157/A, BP-160/R, BP-174
IC-F30/F40, IC-F35/F45	AD-67*	CM-140/141/142*
IC-M15, IC-GM1500	AD-68	CM-138/139/165
IC-M1, IC-M1EURO	AD-69	BP-185/186
IC-F3/F4/S, IC-T2H/A/E, IC-F4SR/TR IC-A4, IC-40S	AD-81	BP-195/196/R
IC-4008A/E/M, IC-4008MKII, IC-446S, IC-40Jr	AD-89	BP-202
IC-F30G/F40G, IC-F3G/F4G, IC-F11/F21/F12/F22, IC-V8, IC-T3H	AD-94*	BP-209/210*/222
IC-F30G/F40G, IC-F3G/F4G, IC-F11/F21/F12/F22, IC-V8, IC-T3H	AD-101**	BP-209/210*/211†, BP-222
IC-M1V, IC-M1EURO V	AD-102†	BP-215†
IC-M2A, IC-M21	AD-103	BP-224

### ◆ Non-PCB type adapters (AD-75 or AD-88 is required)

Transceiver	Charger Adapter	Battery pack
IC-W21/X21, IC-2GX series	AD-28 +AD-75	BP-131/132/157/A BP-160/174
IC-A3/A22	AD-50 +AD-75	CM-166
IC-Z1A/E, IC-W31/W32	AD-51 +AD-75	BP-171/172/173, BP-180
IC-T22/T42, IC-T7A/E/H	AD-56 +AD-75	BP-171/172/173, BP-180
IC-T8, IC-T81, IC-A5/A23	AD-87 +AD-88*	BP-198*/199*/200*/L*

\* AD-67, AD-88, AD-94 and AD-101 have a temperature detection circuit for the Ni-MH battery. When the battery's temperature is outside the charging range, charging stops and the charging indicator flashes until the temperature returns to within the range.

† AD-101 and AD-102 are compatible for charging the Li-Ion battery packs, BP-211 and BP-215, respectively.

The BC-121N may be able to be used with future transceivers not listed above. See the transceiver instruction manual for the appropriate adapter information.

### ◆ How To Charging

- ① Connect the optional OPC-656 DC power cable or the BC-124 AC adapter to the BC-121N as illustrated in the diagram below.
  - No charge indicator lights up.
- ② Insert a battery pack with (or without) the transceiver into a BC-121N charging slot.
  - The corresponded charge indicator lights up in orange.
- ③ When the charge indicator changes to **GREEN**, battery charging is completed.
  - But it is still charging in trickle charge mode when charging Ni-Cd or Ni-MH battery pack.

**CAUTION:** The transceiver power **MUST** be turned **OFF** during charging otherwise:

- The battery will not be charged correctly.
- The battery life may be shortened.

The transceiver cannot be used even while charging.

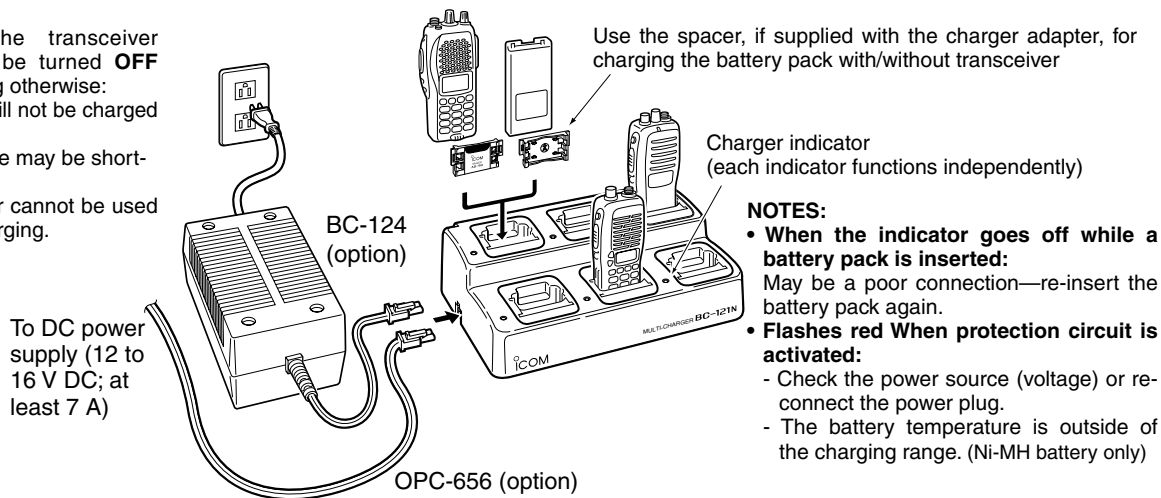

### NOTES:

#### For Ni-Cd/Ni-MH battery packs:

The BC-121N rapidly charges a battery pack to a specified level, not a completed level, to prevent over-charging. Leave the battery pack in the charger for a few more hours (up to 15 hours; depending on battery condition) after the LED indicator turns green, to charge the battery completely.

#### For Li-Ion battery packs:

Li-Ion batteries are different from Ni-Cd batteries in that it is not necessary to completely charge and discharge them to prolong the battery life. Therefore, charging the battery in intervals, not for extended periods, is recommended.

### NOTES:

- **When the indicator goes off while a battery pack is inserted:**

May be a poor connection—re-insert the battery pack again.

- **Flashes red When protection circuit is activated:**

- Check the power source (voltage) or re-connect the power plug.
- The battery temperature is outside of the charging range. (Ni-MH battery only)

# WALL ATTACHMENT AND SPECIFICATIONS

# 3

## ◆ WALL ATTACHMENT

The multi-charger has holes in the rear panel allowing it to be hanged from a wall. Use appropriate screws (6 mm; 1/4 inch diameter) and attach it to a solid surface (capable of withstanding 20 kg of fore).

**CAUTION:** NEVER place anything other than transceivers/batteries into the charger.

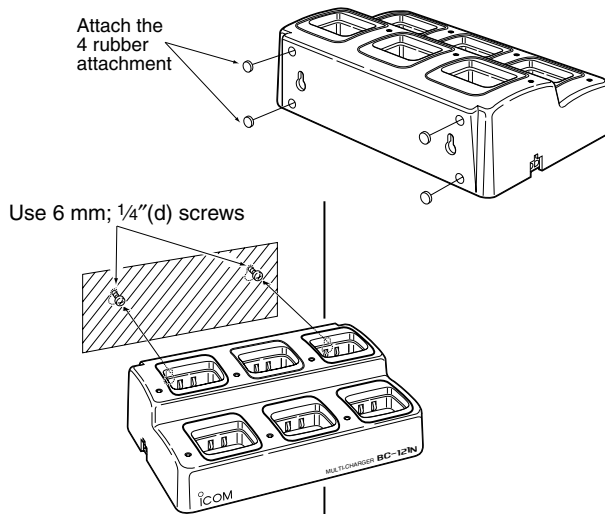

## ◆ SPECIFICATIONS

- Input voltage : 12 to 16 V DC or the specified AC adapter (BC-124)
- Charging current : 840 mA  $\pm$  10% (rapid charging)  
670 mA  $\pm$  10% (rapid charging)  
540 mA  $\pm$  10% (rapid charging)  
420 mA  $\pm$  10% (rapid charging)  
30 mA  $\pm$  10 mA (trickle charging)
- Charging voltage : 8.4 V  $\pm$  0.1 V (Li-Ion battery)
- Charging temperature range : +10°C to +40°C  
(+50°F to +104°F)
- Dimensions (projection not included) : 300(W) $\times$ 197(D) $\times$ 93(H) mm  
(11<sup>13</sup>/<sub>16</sub>(W) $\times$ 7<sup>3</sup>/<sub>4</sub>(D) $\times$ 3<sup>21</sup>/<sub>32</sub>(H) in)
- Weight (approx) : 1.4 kg; 3 lb 1 oz (except BC-124)
- Electrostatic durability : Air discharge 8 kV  
Contact discharge 4 kV

**Count on us!**

A-6133H-1G  
Printed in Japan  
© 2002 Icom Inc.

**Icom Inc.**  
1-1-32 Kamiminami, Hirano-ku, Osaka 547-0003 Japan