

Thank you for choosing this Icom product.
READ ALL INSTALLATION MANUAL carefully and completely before using this product.

1 SUPPLIED ACCESSORIES

The following accessories are supplied with the transceiver. Carefully check the quantity of each part.

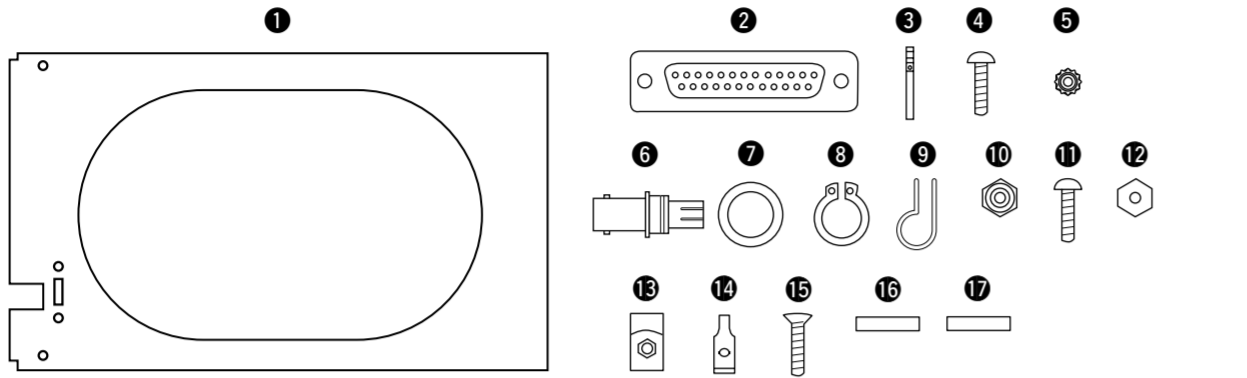

1 Mounting bracket.....	1	11 Screw (No. 6 x 1/2).....	1
2 D-Sub 25 pin connector	1	12 Nut (No. 6)	1
3 Connector pins (M39029/63-368).....	25	13 Crimp nuts (No. 6)	6
4 Screws Bind UNC (No. 4 x 3/8)	2	14 Speed nut UNC (No. 6)	4
5 K-Lock Nut (No. 4)	2	15 Screws (No. 6 x 1/2)	6
6 BNC-LP	1	16 COMM1 sticker	1
7 Washer (Icom washer V)	1	17 COMM2 sticker	1
8 C-shaped ring	1		
9 Antenna cable clip	1		
10 Self crimping nut (No. 6)	1		

The following items are required for installation but are **NOT** supplied with the transceiver.

- VHF antenna for the air communication band
- Various cables
- An antenna cable with a BNC connectors (50 Ω)
- Switches to be mounted on the aircraft yoke
- Headphones (500 Ω)
- Low-impedance carbon or dynamic microphone
- Pre-amplifier for a dynamic microphone

◇ COMM1 and COMM2 stickers

When two transceivers are installed, attach the supplied COMM1 and COMM2 stickers to distinguish one from the another.

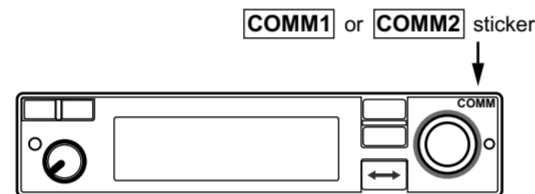

Icom, Icom Inc. and Icom logo are registered trademarks of Icom Incorporated (Japan) in Japan, the United States, the United Kingdom, Germany, France, Spain, Russia, Australia, New Zealand, and/or other countries.

5 INSTALLATION PROCEDURES

1. Check the quantity of parts.
Refer to **1 SUPPLIED ACCESSORIES**.
2. Prepare miscellaneous items required for installation.
Refer to miscellaneous items in **1 SUPPLIED ACCESSORIES**.
3. Prepare the required wiring.
Refer to **7 CONNECTOR INFORMATION** and **8 CONNECTING THE CABLES FOR D-SUB 25 PIN**.
4. Assemble supplied mounting bracket and other parts.
Refer to **9 MOUNTING BRACKET ASSEMBLY**.
5. Cut the mounting hole.
Refer to **10 MARKING A MOUNTING HOLE**.
6. Mount the transceiver into the mounting bracket.
Refer to **11 MOUNTING TO THE BRACKET**.
7. Check the transceiver operation.
Refer to **12 OPERATION CHECK**.

6 PRECAUTIONS

NEVER bend the cables sharply or place the cables too near the aircraft control cables.

DO NOT place the transceiver where hot or cold air blows directly on it.

AVOID placing the transceiver in areas with temperatures below -20°C or above +55°C (-4°F to +131°F).

NEVER connect the transceiver to a power source using reverse polarity. Reverse polarity will damage the transceiver.

To prevent voltage drops, solder or crimp the cable lug when connecting the DC power cable to the power supply.

Use a 50 Ω, vertically polarized, VHF air band antenna. VSWR should be less than 2.5:1.

Mount the antenna on a flat metal surface or install a ground plane of at least 120 cm² (18 in²).

7 CONNECTOR INFORMATION

◇ D-sub 25-pin

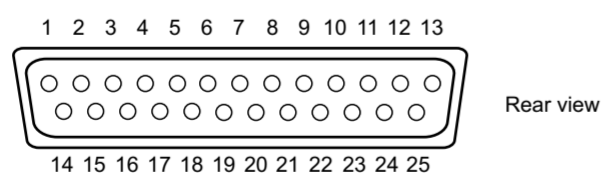

Pin	I/O	Description	Pin	I/O	Description
1	In	Memory Channel Switch*	14	-	Aircraft ground
2	In	Transmit/receive Interlock	15	-	Aircraft ground
3	In	Frequency Exchange Switch*	16	In	PTT*
4	In	DC power ⊕ (13.8/27.5 V)	17	In	Intercom switch*
5	In	DC power ⊕ (13.8/27.5 V)	18	Out	External speaker (4 Ω/5 W)
6	-	RS-232C Serial data (GND)	19	-	External speaker (GND)
7	Out	RS-232C Serial data (TXD)	20	Out	Headphones audio (500 Ω/60 mW)
8	In	RS-232C Serial data (RXD)	21	In	External Dimmer control
9	-	Microphone (GND)	22	-	Headphones audio (GND)
10	In	Microphone 1 (600 Ω)	23	In	Auxiliary audio 3
11	In	Microphone 2 (600 Ω)	24	-	(reserved)
12	In	Auxiliary audio 1	25	-	(reserved)
13	In	Auxiliary audio 2			

*Ground to activate.

2 IMPORTANT

READ THIS INSTALLATION MANUAL CAREFULLY before install the transceiver. This installation manual contains important safety instructions.

NEVER install the transceiver where normal navigation of the aircraft may be hindered.

NEVER install an antenna near any aircraft projection, engine, or propeller.

Install a circuit breaker between the aircraft battery and the transceiver.

Check operation after installation.

Install the transceiver according to the procedures of this installation manual.

The antenna should be spaced at least 50 cm (1.6 feet) from any position occupied by any person on board the aircraft or the vehicle.

3 SPECIFICATIONS

Model	Part Number ¹	Version	Equipment Class	Channel Spacing	Carrier Power
IC-A220	IC-A220T-1-03	USA-06	Receiver: D, E Transmitter: 4, 6	8.33/25.0 kHz	8 W

(1) Part Number

(IC-A220T) - (1) - (03)
Base Part Number - (SW/HW Identifier) - (TSO Minor Change Number)

SW/HW Identifier
1: Hardware Change Only
2: Software Change Only
3: Hardware + Software Change

TSO Minor Change Number
TSO Minor Change Number with initial value 00 and an increment of 1

Operating Temperature Range	-20°C to +55°C. For more details see the Environmental Qualification Form on the Dealers Only page on www.icomamerica.com . The EQF part number is A220-0651-0001.
Environmental Testing	See Environmental Qualification Form on the Dealers Only page on www.icomamerica.com . The EQF part number is A220-0651-0001.

4 INSTALLATION LIMITATION

The conditions and tests required for TSO approval of this article are minimum performance standards. Those installing this article, on or within a specific type or class of aircraft, are responsible for determining that the aircraft installation conditions are suitable for the TSO article.

TSO articles must have separate approval for installation in an aircraft. The article may be installed only if performed under 14 CFR part 43 or the applicable airworthiness requirements.

8 CONNECTING THE CABLES FOR D-SUB 25 PIN

◇ Power cable wiring

Use two pairs of #20 AWG wire for the power and power grounding connections.

Rear view

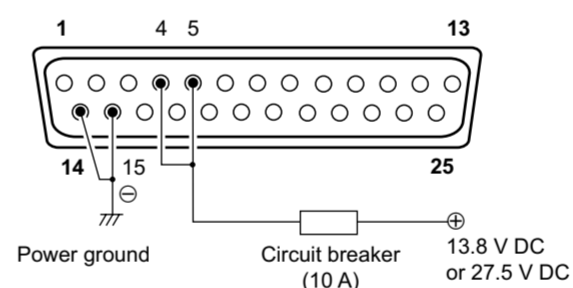

• Circuit breaker

To prevent physical damage, a 10 A circuit breaker **MUST** be installed in the DC power line in the aircraft. Install the circuit breaker in the aircraft breaker panel or instrument panel to ensure easy access during flight.

• Power Ground

Connect the transceiver power ground to the aircraft ground.

◇ Yoke-mounted memory and frequency exchange switches

For the yoke-mounted memory and frequency exchange switches, use a two-position spring loaded rocker switch or two separate momentary push switches.

Rear view

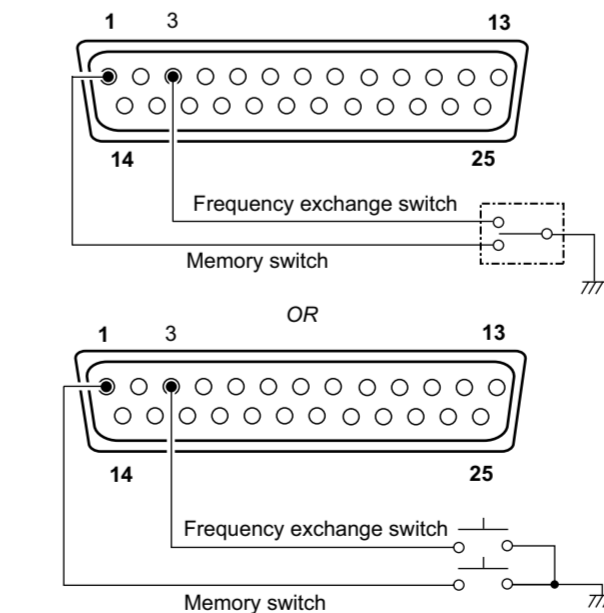

◇ Transmit/receive interlock connections

When two transceivers are installed, connect pin 2 to the other transceiver's PTT line, and connect pin 16 to the other transceiver's interlock line to prevent both transceivers from simultaneously transmitting.

However, when two transceivers are installed through a dual audio panel, the connections are not necessary.

◇ Audio line connections

Use #20 ~ #24 AWG wires for connections.

Rear view

- Two headsets with intercom

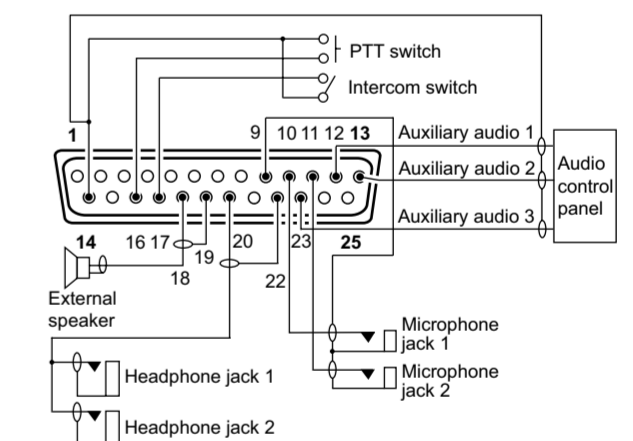

- One headset

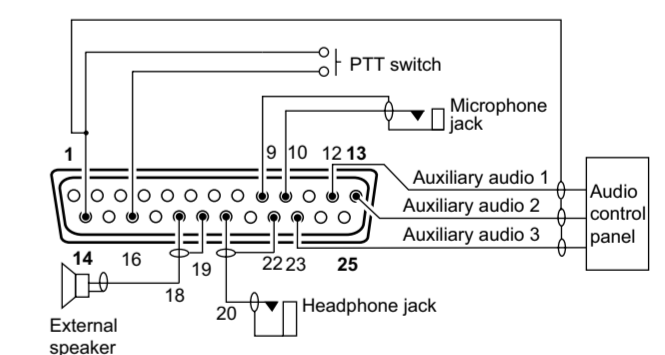

NOTE: If any external intercom system is in use, we recommend that you disable the transceiver's intercom function to prevent degradation of the audio signal. If any degradation exists, leave pin 17 disconnected and disable the transceiver's intercom function by following the steps below.

1. While holding down [DUAL], rotate [VOL] to turn ON the transceiver.
 - The configuration menu is displayed.
2. Rotate [O-DIAL] to select "INCOM MODE."
3. Rotate [DIAL] to set "INCOM MODE" to OFF.
4. Push [RCL] to exit the Configuration menu and restart the transceiver.
 - "ICS" disappears.

9 MOUNTING BRACKET ASSEMBLY

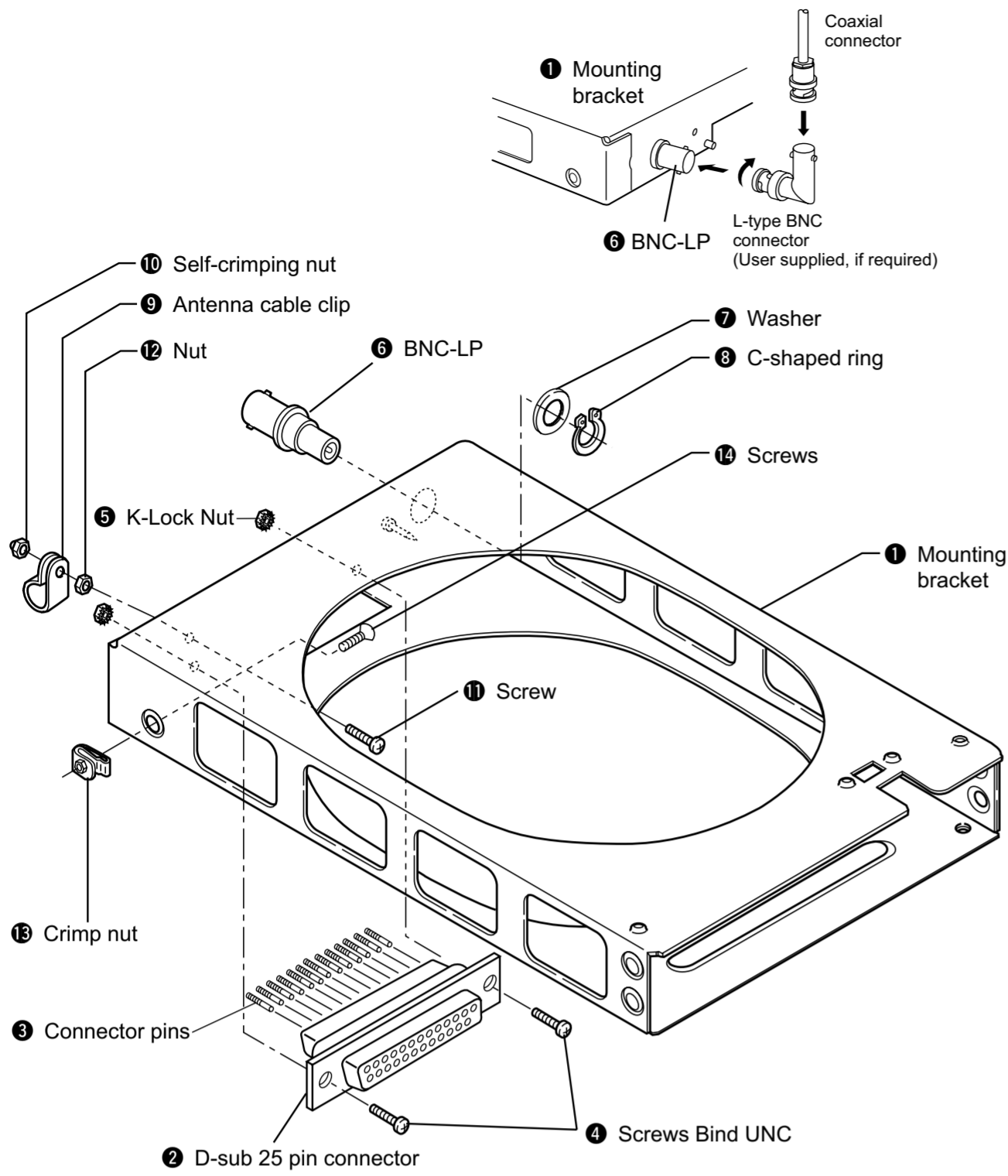

10 MARKING A MOUNTING HOLE

Notes for marking the mounting hole

The transceiver can be mounted securely in the supplied mounting bracket.
Remember to allow adequate space for installation of cables and connectors.
When installing two or more transceivers in a stack, the mounting bracket should be 1.3 mm (0.05") apart.

The mounting bracket has 0.6 mm (0.024") dimples in the top, bottom, and both sides for proper spacing.
Mark and cut the mounting holes.
To support the mounting bracket, the rear mounting bosses should be attached to the airframe.

Mounting bracket dimensions

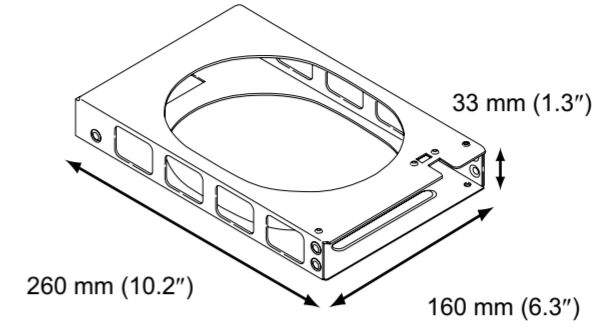

Front panel dimensions

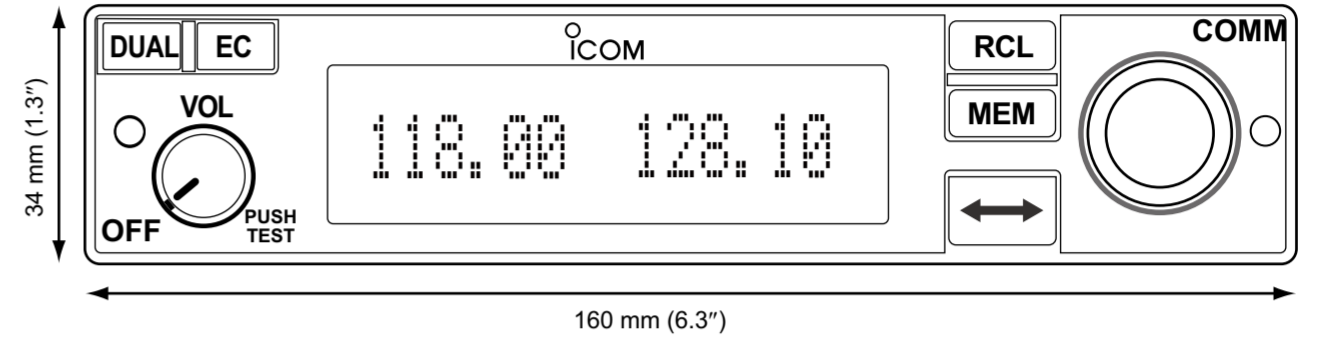

Allow space for the front panel as shown above.

Template

Cut out dimensions for the mounting bracket as follows.

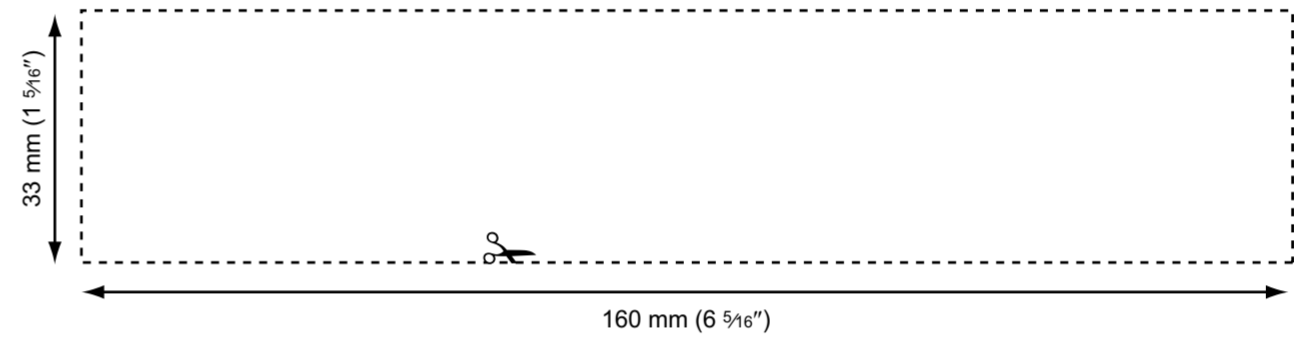

11 MOUNTING TO THE BRACKET

Transceiver installation

- Remove the front panel from the transceiver's main unit.
- Use a 3/32" allen driver.
- Carefully disconnect the cable from the front panel. (Fig. 1)
- Insert a 3/32" allen driver into the lock screw and rotate the driver counterclockwise until the metal catch touches the back of the lock chassis. (Fig. 2)

Main unit front view

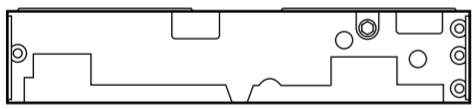

- Insert the main unit (transceiver) into the mounting bracket. (Fig. 3)
- Turn the lock screw clockwise until the main unit (transceiver) is fixed to the bracket. (Fig. 4)
- Connect the cable. (Fig. 5)
- Attach the front panel and tighten the allen screws. (Fig. 5)

Fig. 1

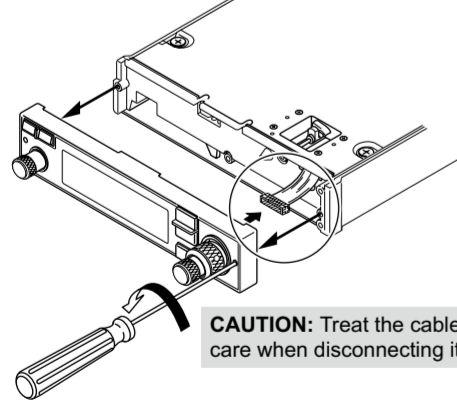

Fig. 4

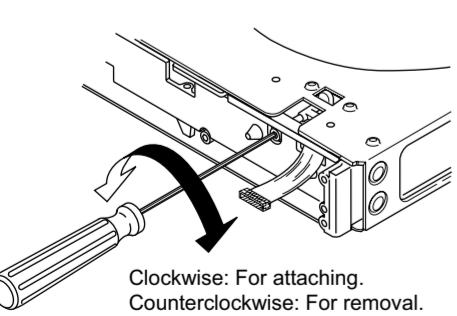

Fig. 2

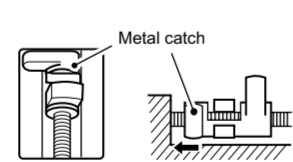

Fig. 5

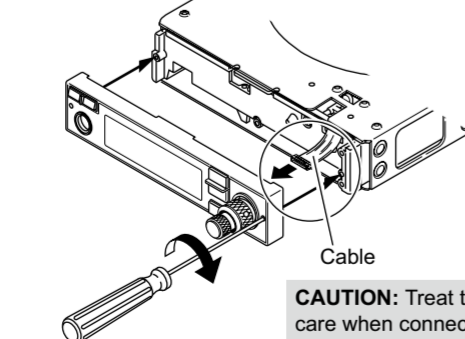
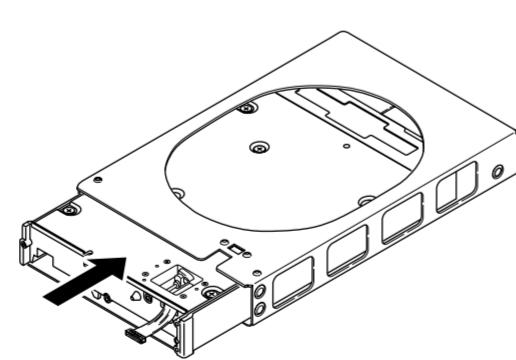

Fig. 3



CAUTION: Make sure that the cable between the transceiver and front panel is securely connected. The transceiver may not function properly when loose or when a wrong connection is made.
Improper cable connection can cause damage and result in a non-warranty repair.

Transceiver removal

The transceiver can be easily removed from the mounting bracket, if required.

- Remove the front panel from the transceiver's main unit.
- Use a 3/32" allen driver.
- Carefully disconnect the cable from the front panel.
- Insert a 3/32" allen driver into the lock screw and rotate the driver counterclockwise until the metal catch touches the back of the lock chassis.
- Slowly pull the transceiver out from the mounting bracket.
- Connect the cable to the front panel.
- Attach the front panel and tighten the allen screws.

12 INFORMATION

TSO Authorization Reference

Function	TSO/RTCA	Applicable SW P/Ns	DO-178C Level
Equipment That Prevents Blocked Channels	TSO-C128a DO-207	A220-0615-0028	C
COM Transceiver	TSO-C169a DO-186B	A220-0615-0028	C

(1) Software Part Number
(A220-0615) - (0028)
(Part Number) - (Version)

Version to be incremented on a minor software change

TSO Deviation list

TSO/ETSO	Deviation
TSO-C128a	1. Icom was granted a deviation from the TSO to mark the exterior of the unit with the serial number instead of the date of manufacture.
	2. Icom was granted a deviation from the TSO to use RTCA/DO-160G instead of the earlier version as the standard for environmental conditions and tests.
	3. Icom was granted a deviation from the TSO to use RTCA/DO-178C instead of the earlier version to demonstrate compliance for the verification and validation of computer software.
TSO-C169a	1. Icom was granted a deviation from the TSO to mark the exterior of the unit with the serial number instead of the date of manufacture.
	2. Icom was granted a deviation from the TSO to use RTCA/DO-160G instead of the earlier version as the standard for environmental conditions and tests.
	3. Icom was granted a deviation from the TSO to use RTCA/DO-178C instead of the earlier version to demonstrate compliance for the verification and validation of computer software.

FCC Grant of Equipment Authorization

Model	FCC ID	IC ID
IC-A220	AFJ297410	202D-297410

Non-TSO function list

These functions operate per the system requirements for this transceiver and do not interfere with the TSO MOPS compliance.

Function	Description
Weather Channels Reception	The radio provides reception of the weather channels which Icom America evaluated as part of the RTCA/DO-160G and RTCA/DO-178C test/verification process and additional system level tests were also performed.
Two Station Intercom	The radio provides a user interface to select two station intercom as an option to the pilot. This function was tested as part of the RTCA/DO-160G and the RTCA/DO-178C test/verification process and additional system level tests were also performed.

12 OPERATION CHECK

Check the following points after transceiver installation.

- Polarity of the power supply.
- **NO** interference caused to other equipment.
- **NO** noise or interference from other equipment.
- VSWR is less than 2.5:1.
- Communication capability on both the highest and lowest communication frequencies, if possible.

Icom America Inc.

12421 Willows Road NE, Kirkland, WA 98034, U.S.A.

Count on us!

Printed in Japan
© 2016-2021 Icom Inc
Basic Issue: May 10/16
Revision 7: Apr 8/21