

POWERVERTER POLE MOUNTED 12/24VDC USB POLE CHARGING UNIT

PASSENGER ACCESSIBLE USB CHARGERS FOR POLE INSTALLATIONS

USB is the preferred method for charging mobile devices on the move. The Alfatronix range of PVPPro chargers can already be seen installed on vehicle walls, seat backs and table tops as well as under seats. The PVPm-S USB charger is designed for applications where journeys are relatively short and passengers are standing for some or all of their time on the vehicle. These units are designed for installation onto vertical poles and offer a robust solution for buses, trams, trains and metro carriages.

The units are designed to be fitted directly to 35mm diameter poles and provide an easily accessible and strong charging solution. These chargers utilise the latest fast charge technology and will seek to communicate with the phone and where compatibility exists, will automatically increase the charge voltage. Using this system, it is possible to provide a useful charging boost even over relatively short time periods.



Designed for integration into passenger vehicles.

Accepts both 12Vdc and 24Vdc.

- Approved to EN50498 and ISO7637-2. E marked (Reg10) and CE marked.
- Quick Charge enabled.
- 2A internal fuse to protect against catastrophic failure.
- Convenient wide input of 9-32Vdc in one standard casing.
- LED indicates unit operational.
- Robust design allows the unit to be grabbed as part of the pole without damage.
- USB connector faces downwards to protect against splashes and avoid connector damage.

It is recommended that these units are fused individually with a 1Amp fuse (24V systems) or a 2Amp fuse (12V Systems).

THE RANGE

The PVPm range has been designed to meet the rigorous standards required for on board commercial vehicle applications including EN50498 and ISO7637-2 and is both CE and E marked (Reg10). The casings are made from V0-rated (self-extinguishing) high impact polycarbonate and the PCB is populated by computer-controlled SMT for maximum accuracy and durability.

WARRANTY

The PVPm Series of Pole mounted USB chargers are manufactured using rugged components to provide years of service in demanding commercial environments and are covered by a three year return to base warranty.



POLE MOUNTED USB CHARGER

Part Number	Description	Dimensions (mm)	Weight
PVPm-S	Pole mounted USB charging unit	113 x 39 x 37	57g

TECHNICAL DATA

Input voltage range	9-32Vdc
Output voltage	5Vdc +/- 0.2V for BC 1.2V and up to 9Vdc for Q.C 3.0
Output power	10W for BC1.2 and 12W for Q.C 3.0
Application	Charges all USB devices Including Apple and Android
Transient voltage protection	Meets ISO7637-2 International standard for 12/24V vehicles and EN61000.4.4 and 4.5
Output noise	<50mV pk-pk
Off load current (quiescent current)	<1.7mA
Power conversion efficiency	90%
Operating temperature	-25°C to +55° to meet this specification table
Storage temperature	-25°C to +100°C
Operating humidity	95% max., non-condensing
Casework	Dark grey polycarbonate body (R118 + EN45545 materials approved)
Connections	Input: 6.3mm push-in flat blade connectors Output: USB type 'A' single socket - tested to 10,000 mating cycles
Output indicator	LED indicates unit operational
Mounting method	Screw mounting to vertical pole (Ø35mm)
Safe area protection:	Over Current Limited by current sensing circuit Over heat Limited by temperature sensing circuit Overvoltage and Undervoltage Limited by sensing circuit Reverse Polarity Limited by sensing circuit Transients Protected by filters and rugged component selection Catastrophic protection Internal fuse
Approvals	2014/30/EU The general EMC directive Regulation 10 The automotive directive 93/68/EEC The CE marking directive
Designed to	EN50498, EN55032, EN50155, EN50121-3-2 & ISO 7637-2.
Markings	CE and E marked
IP Rating:	IP53

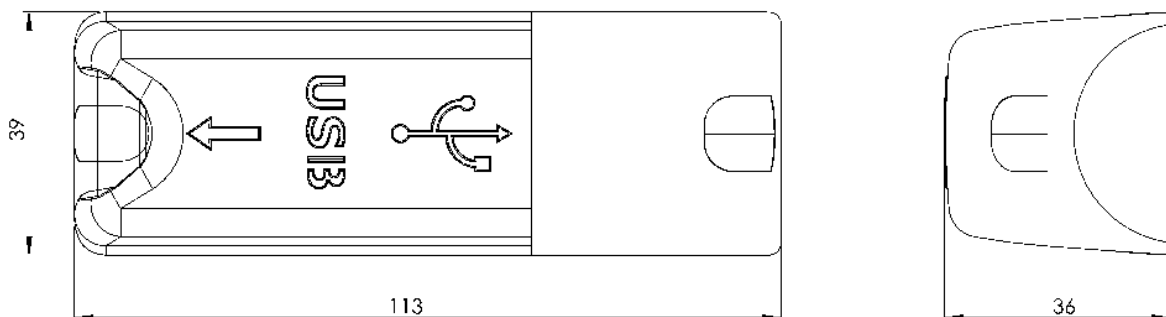

Version: 1905